

Smart Air Circuit Breakers

Smart ACB is a large-capacity breaking, multifunctional device. It is a Susol/Metasol ACB applied with a digital trip relay STU (Smart Trip Unit) with built-in IoT communication function for measurement, analysis, diagnosis and Smart LV implementation other than relay.



Smart ACB

1. Overview	
• Susol ACB Overview	12
• Metasol ACB Overview	14
• STU (Smart Trip Unit) Overview	16
2. Features	
• ACB with STU (Smart Trip Unit) Features	18
3. Model selecting guide	
• Susol ACB model numbering (Product selection)	22
• Metasol ACB model numbering (Product selection)	24
• Susol ACB Cradle model numbering (Product selection)	26
• Metasol Cradle model numbering (Product selection)	26
• Smart Trip Unit model numbering (Product selection)	27
4. Rated specifications	
• Susol ACB Rated specifications	28
• Metasol ACB Rated specifications	30
5. Smart Trip Unit	32



Family

As the world's best large-capacity breaking, multifunctional device, Susol ACB Series can apply digital trip relay STU (Smart Trip Unit) with built-in IoT communication function for measurement, analysis, diagnosis, and Smart LV implementation other than relay. It is suitable for important facilities, since the Arc Cover for securing Arc Space Zero performance is installed.

Full line-up & Compact

Up to 6300A, Susol ACB provides fully lined-up 3 frame. For each frame, there is just one size, which is smaller and more compact. It makes it possible for you to design the optimized volume panel.

85kA

100kA

150kA

AH-06~20D

06	630AF
08	800AF
10	1000AF
13	1250AF
16	1600AF
20	2000AF

Icu=Ics=85kA/500Vac
W=334(3p), 419(4p)mm

AH-06~40E

06	630AF	20	2000AF
08	800AF	25	2500AF
10	1000AF	32	3200AF
13	1250AF	40	4000AF
16	1600AF		

Icu=Ics=100kA/500Vac
W=412(3p), 527(4p)mm

AH-40~63G

40	4000AF
50	5000AF
63	6300AF

Icu=Ics=150kA/500Vac
W=785(3p), 1015(4p)mm

- The highest breaking capacity: 150kA (6300AF at 500Vac)
- 3 ampere frame sizes: 2000/4000/6300AF
- N phase current conducting capacity: 100%



Family

As a large-capacity breaking, multifunctional device, Metasol ACB Series is able to apply digital trip relay STU (Smart Trip Unit) with built-in IoT communication function for measurement, analysis, diagnosis, and Smart LV implementation other than relay. It is a highly customized device that maximizes the range of device selection by size and rating by diversifying small and medium capacity (less than 3200AF) models and various deployments of large capacity (more than 4000AF) models.

Full line-up & Compact

Up to 6300A, Metasol ACB provides fully lined-up 4 frame. For each frame, there is just one size, which is smaller and more compact. It makes it possible for you to design the optimized volume panel.

70kA (65kA)

85kA (70kA)

100kA

120kA

AN-06~16D

06	630AF
08	800AF
10	1000AF
13	1250AF
16	1600AF

Icu=Ics=65kA/500Vac
W=334(3p), 419(4p)mm

AS-06~20D

06	630AF
08	800AF
10	1000AF
13	1250AF
16	1600AF
20	2000AF

Icu=Ics=70kA/500Vac
W=334(3p), 419(4p)mm

AN-20~32E

20	2000AF
25	2500AF
32	3200AF

Icu=Ics=70kA/500Vac
W=412(3p), 527(4p)mm

AS-20~40E

20	2000AF
25	2500AF
32	3200AF
40	4000AF

Icu=Ics=85kA/500Vac
W=412(3p), 527(4p)mm

AS-50F

40	4000AF
50	5000AF

Icu=Ics=100kA/500Vac
W=629(3p), 799(4p)mm

AS-40~63G

40	4000AF
50	5000AF
63	6300AF

Icu=Ics=120kA/500Vac
W=785(3p), 1015(4p)mm

- The highest breaking capacity: 150kA (6300AF at 500Vac)
- 4 ampere frame sizes: 2000/4000/5000/6300AF
- N phase current conducting capacity: 100

Smart Trip Unit (Trip Relay)

It is a smart trip unit that provides the world's highest level of measurement accuracy, relay function, and IoT communication function, and is a relay interlocked with the mechanism (low voltage circuit breaker body). It expands and improves the ACB's breaking performance (high-speed short-circuit breaking characteristic) and increases the ACB life (increasing marking capacity).



Smart Trip Unit

N type



A type



P type



S type



- Secures relay operation safety through the instrument-level measurement accuracy (current/voltage 0.5%, power class 1.0)
- Prevention of mis-trip through powerful self-diagnosis functions such as CT disconnection check, contact wear rate, internal temperature monitoring, and quick response through alarm
- Secures Smart Panel Solution through **ICT convergence technology** (Service is accessible anytime, anywhere)
- Speedily changes the relay setting value when changing from commercial power to power generation according to S type relay setting Group A/B (A→B)
- Power supply for checking and setting internal data of STU (N/A/P/S) at a short distance through USB communication

Serializes STU's trip relay by function

The trip relay series for each use and function are maximized and the user's convenience is maximized by easy attachment and detachment.



N type

- Device operation through self-power
- Current relay function
- Supports USB communication



P type

- Device operation through self-power
- Device operation via AC or DC
- Current/voltage/frequency/power relay function
- 3.5" Graphic Display
- DO output
- Supports USB communication
- Supports RS485 communication



A type

- Device operation through self-power
- Device operation via AC or DC
- Current relay function
- Segment LCD Display
- DO output
- Supports USB communication
- Supports RS485 communication



S type

- Device operation through self-power
- Device operation via AC or DC
- Current/voltage/frequency/power relay function
- 3.5" Graphic Display
- DO output
- Relay setting to group A/B
- Supports short-range USB communication
- Supports RS485 communication
- Supports NFC/BLE communication

ACB with STU (Smart Trip Unit) Features

Upgraded performance compared to existing OCR

Improved measurement accuracy

Type	Susol ACB OCR P/S	Smart Trip Unit (STU)			
		N	A	P	S
Measurement accuracy	Current	6%	0.5%	0.5%	
	Voltage	3%	—	0.5%	
	Power	10%	—	Class 1.0	
	Frequency	0.05 Hz (50, 60 Hz device classification)	50, 60 Hz device classification	0.1% (10~200Hz)	

- Measurement accuracy through calibration using voltage, current, and power reference (Current/Voltage : 0.5%, Power : Class 1.0) Satisfaction
- Improved resolution using 16bit ADC converter

Measurement items & relay function extension

1. Based on S type, equipped with a total of 29 types and 58 relay functions
2. Relay setting grouping and change function (Gtoup A/B)
: Relay group setting is changed quickly in parallel feeding situation where relay setting needs to be changed. (Group A → B)
3. ERMS (Energy Reduction Management System) function
: As a function to sensitively change the relay setting for the safety of a field electrical engineer, it is a safety related function required by the American market (L/S1/S2/IG//LN)
4. ZSI (Zone Select Interlock) function
: A function to operate the upstream circuit breaker closest to the accident point first by using ZSI Input DI and ZSI Output DO
5. Start-up function
: Prevents malfunction of relay element by in-rush current generated when starting motor and Transformers
6. Stores 255 system events, 127 fault events and 6 accident waves
: Trip Wave saves 4 cycles before an accident + 4 cycles after an accident

Safe self-diagnosis function

Quick maintenance by adding powerful self-diagnosis function to prevent mis-trip and through alarm

	N type	A type	P type	S type
LED	RUN/AL LED flashing (Red ↔ Blue flashing)			
LCD		Displays the corresponding segment or error number	Can be checked on the self-diagnosis screen	
Self-diagnosis List	<ul style="list-style-type: none"> • Contact Wear Alarm : Occurs when the contact wear rate is over 80% • Electrical Open Count Over Alarm : Occurs when the electrical open count exceeds 80% of the allowable electrical open count • Mechanical Open Count Over Alarm : Occurs when the mechanical open count exceeds 80% of the allowable mechanical open count • CT disconnection error : Occurs when CT disconnection occurs (monitoring for each phase), breaks relay function related to disconnection such as G, UP, IU, etc. • Over Heat Error : Occurs when CPU internal temperature N/A type exceeds 100°C and P/S type exceeds 115°C. • MTD Fail : Occurs when STU is not assembled with MTD or trip coil disconnection occurs (wiring check) • Battery Low Alarm : Occurs when the internal battery is not inserted or when the battery voltage is low • Rating Plug Unattached or Error : Occurs when rating plug is not assembled or when there is rating plug error • Ampere Frame Error : Occurs when the value of rating plug is not within 45%~100% of AF • Factory Cfg Error : Occurs when the factory mode setting is entered incorrectly • Device Type Error : Occurs when the rating plug information and CT information are different • RTC Error : Occurs when an error occurs in the internal RTC information • Memory Error : Occurs when corruption occurs in the redundant internal settings stored in the internal non-volatile memory 			

Increased user convenience

Uninterrupted device update & non-powered device setting

- By using USB interface, STU Program update is possible without a power outage in the live state, and STU can be set and updated even when the power is not supplied.



Uninterrupted device update & non-powered device setting

Built-in VDM and frequency tracking technology

- With a built-in VDM for voltage measurement, it can save the installation space of the distribution panel. It is also equipped with frequency tracking technology that maintains measurement and relay accuracy even at variable frequencies from 10 Hz to 200 Hz (Able to respond to renewable energy markets such as wind power and waterpower).

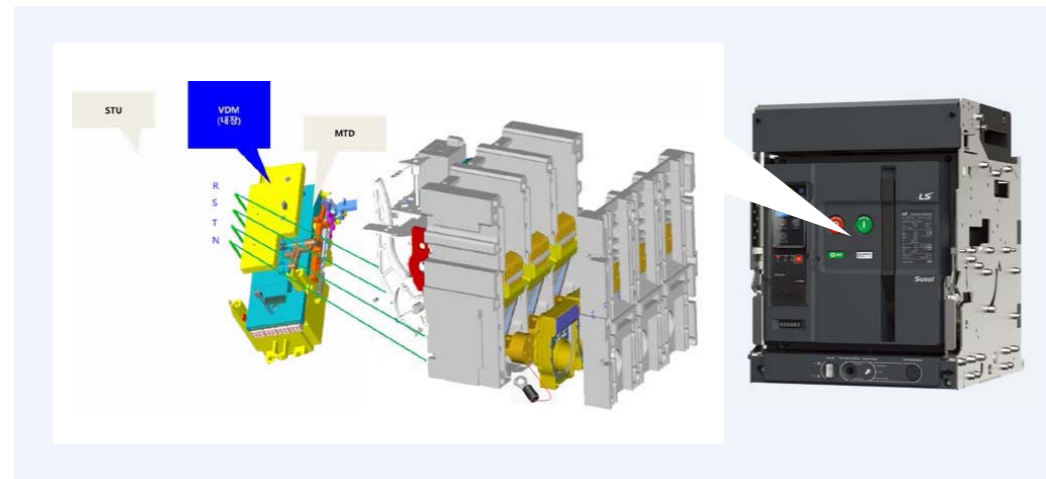

3.5" Touch Graphic LCB applied

- By applying Color Graphic LCD & Touch panel in P and S types, it improves the convenience and visibility of device use.

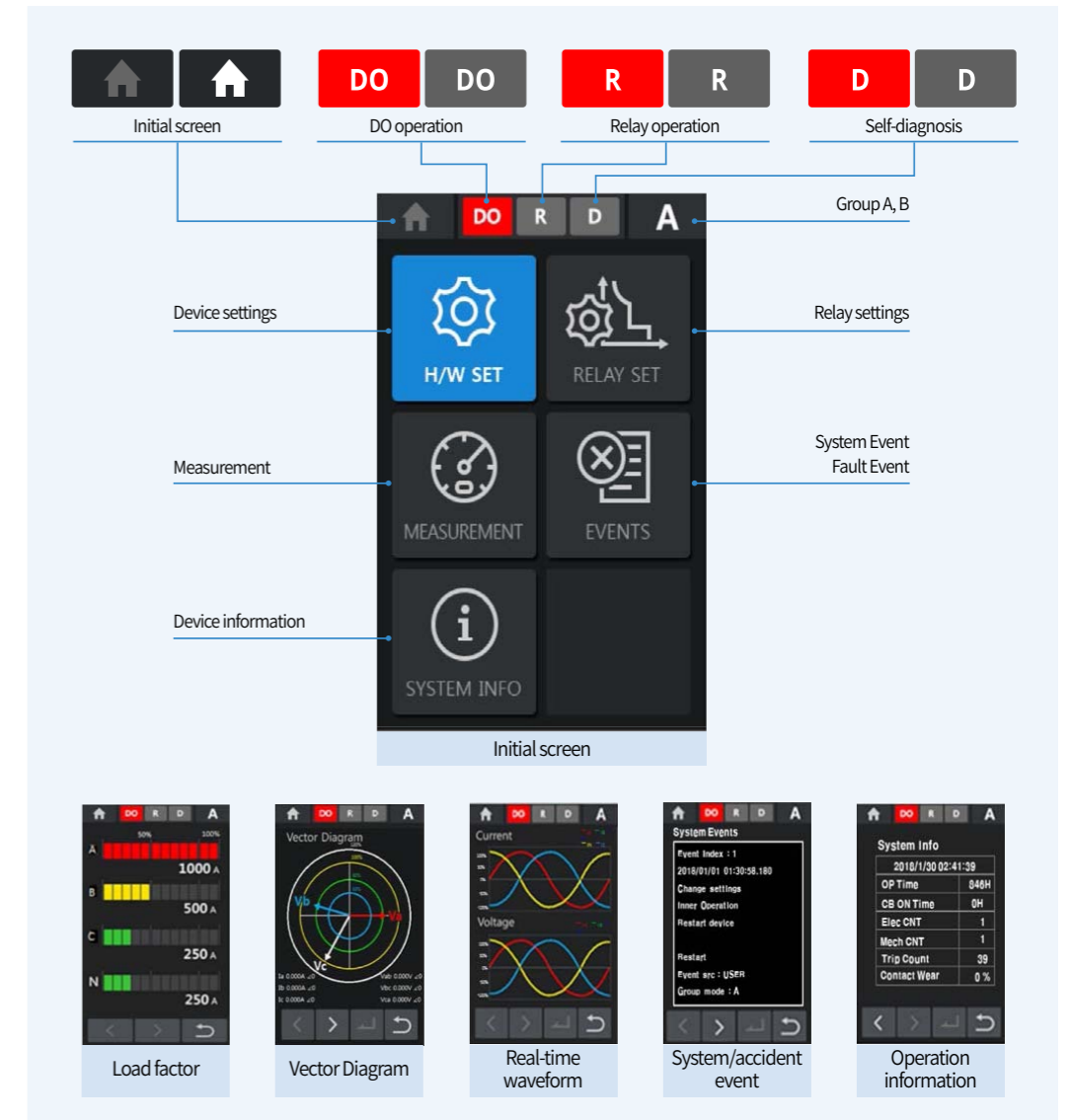

Built-in IoT function

- It is possible to check and share device information on a smartphone by interworking with a mobile App. through BLE and NFC communication.

Type	Specifications
NFC	(1) Collects STU last trip information through smart phone in non-powered state (2) Communication distance : 10mm or less
BLE	(1) All information of the device can be accessed through the smart phone while the power is supplied. (2) Communication distance : within 4m

Model selecting guide

Susol ACB model numbering (Product selection)

Body and accessories

AH	10	D	3	10	A
Type	Ampere Frame	Frame sizes & phase array	No. of pole	Rated current (CT Spec.)	Connections
Susol ACB	06 630AF 08 800AF 10 1000AF 13 1250AF 16 1600AF 20 2000AF	D 630 ~ 2000AF 3P/4P Standard ABC (N) W 630~2000AF 4P Inverse type (N) ABC	3 3P(D) 4 4P(D, W)	00 Without STU & CT 02 200A 04 400A 06 630A 08 800A 10 1000A 13 1250A 16 1600A 20 2000A	Draw-out type A Automatic connection Fixed type H Horizontal type V Vertical type Mixed type M Horizontal Vertical Mixed type N Vertical Horizontal P Front type

**2000AF only offers with vertical type mounting terminals(Busbar).*



E	3	00
Frame sizes & phase array	No. of pole	Rated current (CT Spec.)
E 630 ~ 4000AF 3P/4P Standard ABC (N) X 630 ~ 4000AF 4P Reverse phase type(N) ABC	3 3P(E) 4 4P(E, X)	00 No STU & CT 06 630A 08 800A 10 1000A 13 1250A 16 1600A 20 2000A 25 2500A 32 3200A 40 4000A

**4000AF only offers with vertical type mounting terminals(Busbar).*



G	3	00
Frame sizes & phase array	No. of pole	Rated current (CT Spec.)
G 4000/5000/6300AF 3P/4P Standard ABC (N) Z 4000/5000/6300AF 4P Reverse phase type(N) ABC	3 3P(G) 4 4P(G, Z)	00 No STU & CT 40 4000A 50 5000A 63 6300A

Note 1) AH-20D, AH-40E types are equipped with vertical-only terminals.
In case of F/Y/G/Z Frame size, front type & mixed type connection is not available.
2) In case of DH type Switch Disconnector, the rated current (CT Spec.) will be applied 00
3) DN models are selectable up to 3200AF and DS models up to 4000AF.

M1	D1	D1	AX	SS1	U1	AL
Motor rated voltage	Closing coil rated voltage	Shunt coil rated voltage	Aux.contact & charging types	STU	UVT coil rated voltage	
MA Without Motor M1 AC/DC 100V ~ 130V M2 AC/DC 200V ~ 250V M3 DC 125V M4 DC 24V ~ 30V M5 DC 48V ~ 60V M6 AC 380V ~ 415V M7 AC 440V ~ 480V M8 AC 48V	D0 Without Closing coil D1 AC/DC 100V ~ 130V D2 AC/DC 200V ~ 250V D3 DC 125V D4 DC 24V ~ 30V D5 DC 48V ~ 60V D6 AC 380V ~ 480V D7 AC 48V	D0 Without Shunt coil D1 AC/DC 100V ~ 130V D2 AC/DC 200V ~ 250V D3 DC 125V D4 DC 24V ~ 30V D5 DC 48V ~ 60V D6 AC 380V ~ 480V D7 AC 48V	AX Standard type OFF - Charge 3a3b AC Standard type ON - Charge 3a3b BX Standard type OFF - Charge 5a5b BC Standard type ON - Charge 5a5b HX High capacity OFF - Charge 5a5b HC High capacity ON - Charge 5a5b CC Standard type ON - Charge 6a6b JC High capacity ON - Charge 6a6b GX High capacity OFF - Charge 3a3b GC High capacity ON - Charge 3a3b TX TCS OFF - Charge 4a4b TC TCS ON - Charge 5a5b	Refer to page 27	U0 Without UVT coil U1 AC/DC 100V ~ 130V U2 AC/DC 200V ~ 250V U3 DC 125V U4 DC 24V ~ 30V U5 DC 48V ~ 60V U6 AC 380V ~ 480V U7 AC 48V	

** UVT Delay module is available over AC / DC 48V*

Option		
Option	Type name	Option description
AL	AL1 + MRB	
A1	AL1 + MRB + RES(AC110~130V) *AC only	
A2	AL1 + AL2 + MRB	
A3	AL1 + MRB + RES(AC/DC 110~125V) *DC only	
A4	AL1 + MRB + RES(AC/DC 200~250V) *AC only	
A5	AL1 + MRB + AUTO RESET	
A6	AL1 + AL2 + MRB + AUTO RESET	
A7	AL1 + MRB + RES(AC/DC 110~125V) + AUTO RESET *DC전용	
A8	AL1 + MRB + RES(AC/DC 200~250V) + AUTO RESET *AC전용	
A9	AL1 + MRB + RES(AC/DC 110~130V) + AUTO RESET *AC전용	
Y2	AL1 + AL2 + MRB(2b contact)	
Y6	AL1 + AL2 + MRB + AUTO RESET(2b contact)	
Z2	AL1 + AL2 + MRB(1a1b contact)	
Z6	AL1 + AL2 + MRB + AUTO RESET(1a1b contact)	
C	C	Counter
S	CS2	Charge switch communication
B	B	On/Off Button lock
M	MI	Mechanical interlock
D	DI or MOC	Door Interlock or MOC (Mechanism operated cell switch)
K	K1	Key Lock
K2	K2	Key Interlock Set
K3	K3	Key Lock Double
R	RCS	Ready to Close switch
T	TM	Temperature Monitoring
H1	SHT2	AC/DC 100~130V
H2	SHT2	AC/DC 200~250V
H3	SHT2	DC 125V
H4	SHT2	DC 24~30V
H5	SHT2	DC 48~60V
H6	SHT2	AC 380~480V
H7	SHT2	AC 48V

Note 1)

Note 1) It is a double shunt coil and not applicable when using UVT

Model selecting guide

Susol ACB Cradle model numbering (Product selection)

Cradle

AL	H16D	3	A	H	E	S
Type	Rated current and frame	No. of pole	Terminal connections	Connections	Safety shutter	Arc cover (Zero Arc Space) <small>note)</small>
LS ACB Cradle	H06~16D AH - 06 ~ 16D H20D AH - 20D H06~32E AH - 06 ~ 32E H40E AH - 40E H40~50G AH - 40 ~ 50G H63G AH - 63G	3 3P 4 4P	A Automatic connection J Manual connection	H Horizontal type (H20D inapplicable) V Vertical type M Mixed type Line: Horizontal Load: Vertical (H20D inapplicable) N Mixed type Line: Vertical Load: Horizontal (H20D inapplicable) P Front type (20D, 40E, 50FG, 63G inapplicable)	E Without safety shutter F With safety shutter	S With ARC Cover

*D Frame 2000AF and E Frame 4000AF are vertical type only.

Note) Susol ACB is supplied as an arc cover standard.

Metasol ACB Cradle model numbering (Product selection)

Cradle

AL	N16D	3	J	H	E	N
Type	Rated current and frame	No. of pole	Terminal connections	Connections	Safety shutter	Arc cover (Zero Arc Space)
Metasol ACB Cradle	N06~16D AN - 06 ~ 16D S06~16D AS - 06 ~ 16D S20D AS - 20D N20~25E AN - 20 ~ 25E N32E AN - 32E S20~25E AS - 20 ~ 25E S32E AS - 32E S40E AS - 40E S40~50F AS - 40 ~ 50F S40~50G AS - 40 ~ 50G S63G AS - 63G	3 3P 4 4P	J Without manual access A With automatic connection	H Horizontal type (20D inapplicable) V Vertical type M Mixed type Line: Horizontal Load: Vertical (20D inapplicable) N Mixed type Line: Vertical Load: Horizontal (20D inapplicable) P Front type (20D, 40E, 50FG, 63G inapplicable)	E Without safety shutter F With safety shutter	N Without ARC Cover S With ARC Cover

*D Frame 2000AF and E Frame 4000AF are vertical type only.

Smart Trip Unit model numbering (Product selection)

N type



N	G	G
STU TYPE	Communication & short circuit detection	Control power & frequency
N Normal	H No communication + ground fault (Residual earth fault protection)	0 No control power, 60 Hz 5 No control power, 50 Hz

Accident indication can be confirmed only by LED

A type



A	G	D
STU TYPE	Communication & earth leakage detection	Control power & frequency
A Ammeter	H No communication + ground fault (Residual earth fault protection) U No communication + earth leakage detection (Earth leakage protection) F No communication + exterior CT ground fault W No communication + PTA	0 No control power, 60 Hz 1 AC/DC 110V ~ 220V, 60Hz 5 No control power, 50 Hz 6 AC/DC 110V~220V, 50Hz

*Communication is impossible without control power (AD0, AJ0, AY0, AO0, AB0, AD5, AJ5, AY5, AO5, AB5 cannot be implemented)

*There is no L, S, I, G output contact, without control power, (only OCR LED can be checked) - No output contact for AH0, AH5, AM0, AM5, AF5, AW0, AW5

P type



P	S	0
STU TYPE	Communication + Gext, relay element other than NCT	Control power & frequency
P Power meter	S Communication + Gext, relay element other than NCT J Communication + earth leakage detection (Earth leakage protection) Y Communication + exterior CT ground fault O Communication + NCT can be used	1 AC/DC 110V ~ 220V, 60Hz 6 AC/DC 110V ~ 220V, 50Hz

S type



S	S	0
OCR TYPE	Communication + Gext, relay element other than NCT	Control power & frequency
S Supreme meter	S Communication + Gext, relay element other than NCT J Communication + earth leakage detection (Earth leakage protection) Y Communication + exterior CT ground fault O Communication + NCT can be used	1 AC/DC 110V ~ 220V, 60Hz 6 AC/DC 110V ~ 220V, 50Hz

Rated specifications

Susol ACB



Frame		AH - D						AH - E									AH - G						
Type		AH - 06D	AH - 08D	AH - 10D	AH - 13D	AH - 16D	AH - 20D	AH - 06E	AH - 08E	AH - 10E	AH - 13E	AH - 16E	AH - 20E	AH - 25E	AH - 32E	AH - 40E	AH - 40G	AH - 50G	AH - 63G				
Ampere frame	(AF)	630	800	1000	1250	1600	2000	630	800	1000	1250	1600	2000	2500	3200	4000	4000	5000	6300				
Rated current (I _n max)	(A)	200	400	630	630	800	1000	400	400	630	630	800	1000	1250	1600	2000	2000	2500	3200				
		400	630	800	800	1000	1250	630	630	800	800	1000	1250	1600	2000	2500	3200	4000	4000				
		630	800	1000	1250	1600	2000	800	800	1000	1250	1600	2000	2500	3200	4000	4000	5000	6300				
Rated operational voltage (U _e)	(V)	690						690									690						
Rated insulation voltage (U _i)	(V)	1000						1000									1000						
Frequency	(Hz)	50/60						50/60									50/60						
Number of poles	(P)	3/4						3/4									3/4						
Setting current *	(A)	Control trip relay (... × I _n max)						0.4 ~ 1.0									0.4 ~ 1.0						
N pole rated current	(A)	630	800	1000	1250	1600	2000	630	800	1000	1250	1600	2000	2500	3200	4000	4000	5000	6300				
Rated breaking current (I _{cu}) (Sym)	(kA)	IEC 60947-2 KSC 4620	AC	690V / 600V / 550V ***				65				85				100							
				500V / 480V / 460V				85				100				150							
				415V / 380V / 230V / 220V				85				100				150							
Rated service breaking capacity (I _{cs})	(kA)	...% × I _{cu}				100				100				100									
Rated input current (I _{cm}) (peak)	(kA)	IEC 60947-2 KSC 4620	AC	690V / 600V / 550V ***				143				187				220							
				500V / 480V / 460V				187				220				330							
				415V / 380V / 230V / 220V				187				220				330							
Rated short-time current (I _{cw})	(kA)	1 second				65				85				100									
		2 seconds				60				75				85									
		3 seconds				50				65				75									
Rated impulse withstand voltage (U _{imp})	(kV)	12						12									12						
Operating time (t)	(ms)	Total cut-off time, maximum						40						40									
		Input time						80						80									
Life cycle	ACB (time)	Mechanical						20000						15000									
		Electrical						5000						5000						2000			
Weight (3P/4P)	(kg)	Draw-out type	Body + cradle	Electric charging method				63/74				70/85				87/103				107/139			
				Manual charging method				61/72				68/83				85/101				102/145			
		Fixed type	Electric charging method				29/32				33/40				44/55				65/85				
			Manual charging method				34/44				38/47				44/55				61/81				
Connections **	Fixed type/ Draw-out type	Horizontal type				●	●	●	●	●	—	●	●	●	●	●	●	○	○	○			
		Vertical type				○	○	○	○	○	●	○	○	○	○	○	○	●	●	●			
		Flat surface type				○	○	○	○	○	—	○	○	○	○	○	○	—	—	—			
		Mix type				○	○	○	○	○	—	○	○	○	○	○	○	—	—	—			
External dimensions	Withdrawal type (mm)	H : 430 (460), D : 375				W (3P/4P)				334/419				412/527				785/1015					
	Stationary type (mm)	H : 300, D : 295				W (3P/4P)				300/385				378/493				751/981					
Certificate & Approval		KS / KEMA / KERI / GOST / CCC						KS / KEMA / KERI / GOST / KEPIC / CCC									KS / KEMA / KERI / GOST / CCC						
Certificate & Approval		LR, ABS, DNV, KR, BV, GL, RINA, NK						LR, ABS, DNV, KR, BV, GL, RINA, NK									LR, ABS, DNV, KR, BV, GL, RINA, NK						

*Refer to detailed STU rating ●: Standard ○: Option
 ***Acquired KSC 4620 rated voltage is 690/600V, and low rated use voltage is KS certified with 600V breaking capacity (Reason: Refer to the classification of KSC 4620 audit criteria certification)
 ** Life time is the lifespan, not the warranty life, and is charged for maintenance. If an abnormality occurs in the accessory device during use, it can be replaced and used.
 Quality Assurance : Based on IEC60947-2 number of opening and closing times within the warranty period
 ※ D Frame 2000AF and E Frame 4000AF are available in vertical type only.

※ Although reverse connection to the power supply and load side is possible, use it as a normal connection for maintenance, inspection, and safety.
 ※ The neutral pole of the 4-pole type is broke by pre-input.
 ※ Rated current brackets are rated for ACB for nuclear power plants.
 1) Test specifications : KEPIC EED 1200/END 1100 / END 2000 2) Nuclear power plant electrical class : Class 1E, Quality class : Q 3) Rated : AC 508V, 100KA, 800/1600/2000/3200A

Rated specifications



Metasol ACB

Frame		AN - D					AS - D						AS - E				AS - F		AS - G											
Type		AN - 06D	AN - 08D	AN - 10D	AN - 13D	AN - 16D	AS - 06D	AS - 08D	AS - 10D	AS - 13D	AS - 16D	AS - 20D	AS - 20E	AS - 25E	AS - 32E	AS - 40E	AS - 40F	AS - 50F	AS - 40G	AS - 50G	AS - 63G									
Ampere frame	(AF)	630	800	1000	1250	1600	630	800	1000	1250	1600	2000	2000	2500	3200	4000	4000	5000	4000	5000	6300									
Rated current (I _n max)	(A)	200	400	630	630	800	200	400	630	630	800	1000	400, 630,	1250	1600	2000	2000	2500	2000	2500	3200	3200								
		400	630	800	800	1000	400	630	800	800	1000	1250	800, 1000,	1600	2000	2500	2500	3200	3200	3200	4000	4000								
		630	800	1000	1000	1250	630	800	1000	1000	1250	1600	1250, 1600,	2000	2500	3200	3200	4000	4000	4000	5000	5000								
Rated operational voltage (U _e)	(V)	690					690						690				690		690											
Rated insulation voltage (U _i)	(V)	1000					1000						1000				1000		1000											
Frequency	(Hz)	50/60					50/60						50/60				50/60		50/60											
Number of poles	(P)	3/4					3/4						3/4				3/4		3/4											
Setting current *	(A)	Control trip relay (... × I _n max)					0.4 ~ 1.0						0.4 ~ 1.0				0.4 ~ 1.0		0.4 ~ 1.0											
N pole rated current	(A)	630	800	1000	1250	1600	630	800	1000	1250	1600	2000	630, 800, 1000, 1250, 1600, 2000	2500	3200	4000	4000	5000	4000	5000	6300									
Rated breaking current (I _{cu})	(kA)	IEC 60947-2 KSC 4620	AC	690V / 600V / 550V ***					65						85				85		100									
				500V / 480V / 460V					70						85				100		120									
				415V / 380V / 230V / 220V					70						85				100		120									
Rated service breaking capacity (I _{cs})	(kA)	...% × I _{cu}					100						100				100		100											
Rated input current (I _{cm}) (peak)	(kA)	IEC 60947-2 KSC 4620	AC	690V / 600V / 550V ***					143						187				187		220									
				500V / 480V / 460V					154						187				220		264									
				415V / 380V / 230V / 220V					154						187				220		264									
Rated short-time current (I _{cw})	(kA)	1 second					65						85				85		100											
		2 seconds					50						75				75		85											
		3 seconds					42						65				65		75											
Rated impulse withstand voltage (U _{imp})	(kV)	12					12						12				12		12											
Operating time (t)	(ms)	Total cut-off time, maximum					40						40				40		40											
		Input time					80						80				80		80											
Life cycle	ACB (time)	Mechanical					20000						15000				10000		10000											
		Electrical					5000						5000				2000		2000											
Weight (3P/4P)	(kg)	Draw-out type	Body + cradle	Electric charging method					63/74						70/85				87/103		107/139		145/173		181/223		186/230			
				Manual charging method					61/72						63/83				85/101				102/145		143/171		179/221		184/228	
		Fixed type	Electric charging method					29/32						33/40				44/50				65/85		78/90		97/117		102/124		
			Manual charging method					34/44						34/44				38/47				44/55				61/81		76/94		98/123
Connections **		Fixed type/ Draw-out type	Horizontal type					●						●				○		○		○		○						
			Vertical type					○						○				○				●		●		●				
			Flat surface type					○						○				○				-		-		-				
			Mix type					○						○				○				-		-		-				
External dimensions	Draw-out type (mm)	H : 430 (460), D : 375			W (3P/4P)			334/419					412/527				629/799		785/1015											
	Fixed type (mm)	H : 300, D : 295			W (3P/4P)			300/385					378/493				597/767		751/981											
Certificate & Approval		KEMA / KERI / KS / GOST					KEMA / KERI / KS / GOST						KEMA / KERI / KS / GOST				KEMA / KERI / KS / GOST / KEPIC													
Marine classification		-					LR, ABS, DNV, KR, BV, GL, RINA, NK						LR, ABS, DNV, KR, BV, GL, RINA, NK				LR, ABS, DNV, KR, BV, GL, RINA, NK													

*Refer to detailed STU rating **●: Standard ○: Option
 ***Acquired KSC 4620 rated voltage is 690/600V, and low rated use voltage is KS certified with 600V breaking capacity (Reason: Refer to the classification of KSC 4620 audit criteria certification)
 ※ Life time is the lifespan, not the warranty life, and is charged for maintenance. If an abnormality occurs in the accessory device during use, it can be replaced and used.
 Quality Assurance : Based on IEC60947-2 number of opening and closing times within the warranty period ※ D Frame 2000AF and E Frame 4000AF are available in vertical type only.

※ Although reverse connection to the power supply and load side is possible, use it as a normal connection for maintenance, inspection, and safety.
 ※ The neutral pole of the 4-pole type is broke by pre-input.
 ※ Rated current brackets are rated for ACB for nuclear power plants.
 1) Test specifications : KEPIC EED 1200/END 1100 / END 2000 2) Nuclear power plant electrical class : Class 1E, Quality class : Q 3) Rated : AC 508V, 100KA, 3200/4000A

Advanced Trip Relay!

With the world's best measurement accuracy and increased relay elements, the relay operation stability is enhanced, and the abnormal self-diagnosis function prevents mis-trips and ensures the stability of abnormal conditions through alarms.

NFC and Bluetooth built-in and Smart add-on modules can be configured. Monitoring and monitoring is possible through service access anytime, anywhere by securing a Smart LV solution through ICT convergence technology.

STU function-specific series



N type

- Device operation through self-power
- Current relay function
- Supports USB communication



A type

- Device operation through self-power
- Device operation via AC or DC
- Current relay function
- Segment LCD Display
- DO output
- Supports USB communication
- Supports RS485 communication



P type

- Device operation through self-power
- Device operation via AC or DC
- Current/voltage/frequency/power relay function
- 3.5" Graphic Display
- DO output
- Supports USB communication
- Supports RS485 communication



S type

- Device operation through self-power
- Device operation via AC or DC
- Current/voltage/frequency/power relay function
- 3.5" Graphic Display
- DO output
- Relay setting group A/B available
- Supports USB communication
- Supports RS485 communication
- NFC/BLE communication support



Types of STU

	Type N	Type A	Type P	Type S
Exterior				
Current relay	• L (N), S, I, G, PTA	• L (N), S, I, G, PTA, Gext	• L (N), S, I, G, PTA, Gext • D, S (V), IU	• L (N), S1, S2, I, G, PTA, Gext • D, S (V) 1, S (V) 2
Voltage relay			• UV, OV, RV, VU	• UV1, UV2, OV1, OV2, RV, VU
Frequency relay			• UF, OF, ROCOF	• UF1, UF2, OF1, OF2, ROCOF
Power relay			• RP, RQ, OP, OQ, UP	• RP, RQ1, RQ2, OP, OQ, UP
Group control				• A, B (can be changed by communication)
Relay fine adjustment			• L, S, I Pickup current	
ERMS		• Control by DI and communication	• Control by DI and communication	• Control by DI and communication
IDMTL support	• Supports L relay element Thermal and DT, SIT, VIT, EIT, EIT50	• Supports L relay element Thermal and DT, SIT, VIT, EIT, EIT50	• Supports L relay element Thermal and DT, SIT, VIT, EIT, EIT50	• Supports L relay element Thermal and DT, SIT, VIT, EIT, EIT50
Trip information maintenance LED	• L, S, I, G/PTA, SP	• L, S, I, G/Gext/PTA, SP	• L, S, I, G/Gext/PTA, SP	• L, S, I, G/Gext/PTA, SP
Screen		• 32 accident events indicated [Accident phase/current/time]	• 127 accident events indicated [Accident phase/current/time]	• 127 accident events indicated [Accident phase/current/time]
Accident record				
Memory	• 127 accident events indicated [Accident phase/current/time]	• 127 accident events indicated • 6 accident events indicated [Does not support Self-power]	• 127 accident events indicated • 6 accident events indicated [Does not support Self-power]	• 127 accident events indicated • 6 accident events indicated [Does not support Self-power]

STU types and main functions

	Type N	Type A	Type P	Type S
Measurement function	<ul style="list-style-type: none"> • Current [R/S/T/N] • Current phase (A phase current standard) • Vector sum image current • Normal and reverse phase current • Current imbalance rate • Current demand before each phase 	<ul style="list-style-type: none"> • Current [R/S/T/N] • External CT current • Current phase (Based on phase A current) • Vector sum image current • Normal and reverse phase current • Current imbalance rate • Current demand before each phase 	<ul style="list-style-type: none"> • 3-phase phase voltage, line voltage • Current [R/S/T/N] • Frequency • External CT current • Voltage/current phase (Based on phase A voltage) • Total/each phase power [P, Q, S] • Total/each power factor • Positive/reverse, effective/invalid/apparent energy • Vector Sum image voltage • Vector sum image current • Normal and reverse phase voltage • Normal and reverse phase current • Voltage unbalance rate • Current imbalance rate • Current demand before each phase • Demand on the last apparent, reactive, or active power 	<ul style="list-style-type: none"> • 3-phase phase voltage, line voltage • Current [R/S/T/N] • Frequency • External CT current • Voltage/current phase (Based on phase A voltage) • Total/each phase power [P, Q, S] • Total/each power factor • Positive/reverse, effective/invalid/apparent energy • Vector Sum image voltage • Vector sum image current • Normal and reverse phase voltage • Normal and reverse phase current • Voltage unbalance rate • Current imbalance rate • Current demand before each phase • Demand on the last apparent, reactive, or active power
Measurement accuracy	<p>Current 0.5%</p> <p>Voltage</p> <p>Power</p> <p>Frequency 50, 60 Hz device classification</p>	<p>0.5%</p> <p></p> <p></p> <p>50, 60 Hz device classification</p>	<p>0.5%</p> <p>0.5%</p> <p>class 1.0 (IEC 62053 - 21, 22)</p> <p>0.1% (10 ~ 200Hz)</p>	<p>0.5%</p> <p>0.5%</p> <p>class 1.0 (IEC 62053 - 21, 22)</p> <p>0.1% (10 ~ 200Hz)</p>
PQ function	<ul style="list-style-type: none"> • 63rd harmonic current • Current THD, TDD, K - Factor 	<ul style="list-style-type: none"> • 63rd harmonic current • Current THD, TDD, K - Factor 	<ul style="list-style-type: none"> • 63rd harmonic current • Voltage THD • Current THD, TDD, K - Factor 	<ul style="list-style-type: none"> • 63rd harmonic current • Voltage THD • Current THD, TDD, K - Factor
Measurement record	<ul style="list-style-type: none"> • Max Current demand • Max I_o • Max I_n • Max internal temperature 	<ul style="list-style-type: none"> • Max Current demand • Max I_o • Max Ext I_o • Max I_n • Max internal temperature 	<ul style="list-style-type: none"> • Max Current demand • Max active/reactive/apparent power • Demand • Max active power • Max V_o • Max I_o • Max Ext I_o • Max I_n • Max internal temperature 	<ul style="list-style-type: none"> • Max Current demand • Max active/reactive/apparent power • Demand • Max active power • Max V_o • Max I_o • Max Ext I_o • Max I_n • Max internal temperature
Real - time waveform		<ul style="list-style-type: none"> • Can be checked by communication 	<ul style="list-style-type: none"> • Can be checked by communication • Can be checked on the LCD screen 	<ul style="list-style-type: none"> • Can be checked by communication • Can be checked on the LCD screen

	Type N	Type A	Type P	Type S
Communication	<ul style="list-style-type: none"> • USB [for on-site operator] (Communication type only) 	<ul style="list-style-type: none"> • USB [for on-site operator] • RS485 / Modbus (Communication type only) 	<ul style="list-style-type: none"> • USB [for on-site operator] • RS485 / Modbus 	<ul style="list-style-type: none"> • USB [for on-site operator] • RS485 / Modbus • BLE • NFC
Power	<ul style="list-style-type: none"> • [Operation when 30% or more of rated current, based on single-phase load standard] 	<ul style="list-style-type: none"> • [Operation when 30% or more of rated current, based on single-phase load standard] • AC/DC 88 ~ 264V • DC 24 ~ 48V(Future development) 	<ul style="list-style-type: none"> • [Operation when 30% or more of rated current, based on single-phase load standard] • AC/DC 88 ~ 264V • DC 24 ~ 48V(Future development) 	<ul style="list-style-type: none"> • [Operation when 30% or more of rated current, based on single-phase load standard] • AC/DC 88 ~ 264V • DC 24 ~ 48V(Future development)
Event record	<ul style="list-style-type: none"> • 255 device status changes [Details, status, date] 	<ul style="list-style-type: none"> • 255 device status changes [Details, status, date] 	<ul style="list-style-type: none"> • 255 device status changes [Details, status, date] 	<ul style="list-style-type: none"> • 255 device status changes [Details, status, date]
Clock	<ul style="list-style-type: none"> • RTC built-in (Back up with battery) 	<ul style="list-style-type: none"> • RTC built-in (Back up with battery) 	<ul style="list-style-type: none"> • RTC built-in (Back up with battery) 	<ul style="list-style-type: none"> • RTC built-in (Back up with battery)
Other LED	<ul style="list-style-type: none"> • Run, alarm, Self-diagnosis, comm. 	<ul style="list-style-type: none"> • Run, alarm, Self-diagnosis, comm. 	<ul style="list-style-type: none"> • Run, alarm, Self-diagnosis, comm. 	<ul style="list-style-type: none"> • Run, alarm, Self-diagnosis, comm.
Operation button	<ul style="list-style-type: none"> • Reset button 	<ul style="list-style-type: none"> • Reset/menu/tap/up/down/enter 	<ul style="list-style-type: none"> • Reset button • LCD Touch 	<ul style="list-style-type: none"> • Reset button • LCD Touch
LED	<ul style="list-style-type: none"> • RUN/AL LED flashing (Red ↔ Blue flashing) 	<ul style="list-style-type: none"> • RUN/AL LED flashing (Red ↔ Blue flashing) 	<ul style="list-style-type: none"> • RUN/AL LED flashing (Red ↔ Blue flashing) 	<ul style="list-style-type: none"> • RUN/AL LED flashing (Red ↔ Blue flashing)
LCD		<ul style="list-style-type: none"> • Displays the corresponding segment or error number on the LCD 	<ul style="list-style-type: none"> • Can be checked on the LCD self-diagnosis screen 	<ul style="list-style-type: none"> • Can be checked on the LCD self-diagnosis screen
Self-diagnosis List	<ul style="list-style-type: none"> • Battery Low Alarm : Occurs when the internal battery is not inserted or when the battery voltage is low • Rating Plug Unattached or Error : Occurs when rating plug is not assembled or when there is rating plug error • Ampere Frame Error : Occurs when the value of rating plug is not within 45%~100% of AF • MTD Fail : Occurs when STU is not assembled with MTD or trip coil disconnection occurs • Factory Cfg Error : Occurs when the factory mode setting is entered incorrectly • Device Type Error : Occurs when the rating plug information and CT information are different • Over Heat Error : Occurs when CPU internal temperature N/A type exceeds 100 degrees and P/S type exceeds 115 degrees • Contact Wear Alarm : Occurs when CPU internal temperature N/A type exceeds 100 degrees and P/S type exceeds 115 degrees • Electrical Open Count Over Alarm : Occurs when the electrical open count exceeds 80% of the allowable electrical open count • Mechanical Open Count Over Alarm : Occurs when the mechanical open count exceeds 80% of the allowable mechanical open count • RTC Error : Occurs when an error occurs in the internal RTC information • Memory Error : Occurs when corruption occurs in the redundant internal settings stored in the internal non-volatile memory • CT disconnection error : Occurs when CT disconnection occurs (monitoring by each phase) 			

Control circuit diagram

This diagram is based on "CONNECTED" position of a circuit breaker and Opening, Motor charging,

Releasing of locking plate should be normal condition.

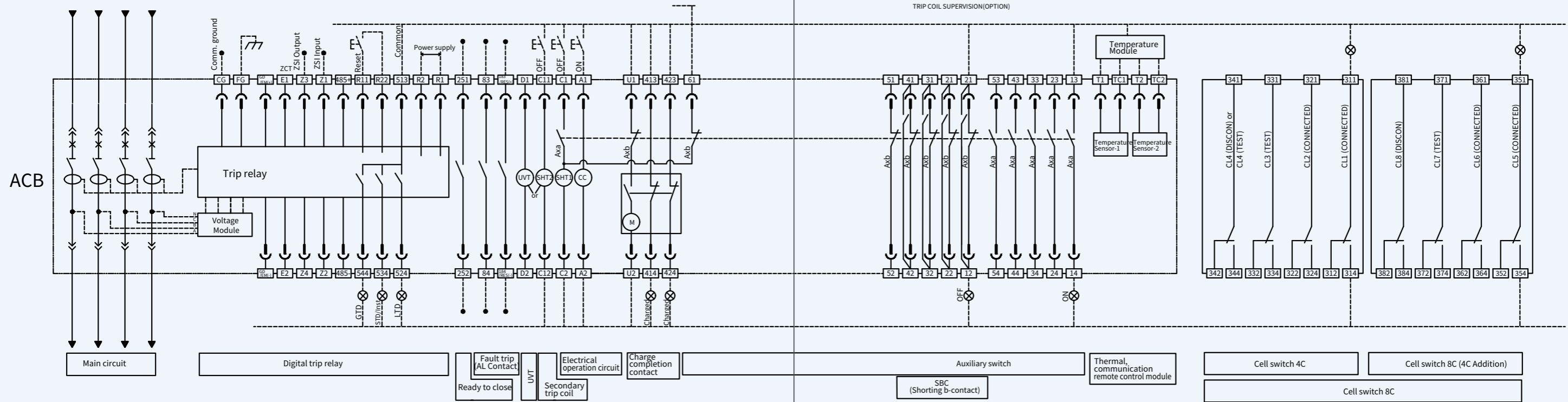

Terminal code description

13 14 ~ 63 64	Auxiliary switch "NO"	D1 D2	Voltage input terminal of UVT	Z1 Z2	ZSI input
11 12 ~ 61 62	Auxiliary switch "NC"	83 84	Alarm1 "NO"	Z3 Z4	ZSI output
413 414	Charged signal	183 184	Alarm2 "NO"	E1 E2	ZCT
423 424	Charged signal communication	251 252	Ready to close switch	EP (EMO) EP (EMO)	Group DI or ERMS DI
U1 U2	Motor charging	R1 R2	Control Power	FG	Frame ground
A1 A2	Closing coil	513 ~ 544	Alarm contact	CG	Communication Ground
C1 C2	Shunt trip	R11 R22	Alarm reset (Trip cause LED, Alarm contact)	TC1 TC2 ~ T1 T2	Temperature module
C11 C12	2nd shunt trip	485+ 485-	RS-485 communication	311 ~ 344	Position switch
				911 ~ 914	EARTHING TRUCK

Accessory code description

Axa , Axb	Auxiliary switch
LTD	Long time delay trip indicator
STD/Inst	Short time delay/instantaneous
GTD	Ground fault trip indicator
CL1-CL4	Cell switch
M	Motor
CC	Closing coil
SHT1	Shunt tripping device 1
SHT2	Shunt tripping device 2
UVT	UVT coil

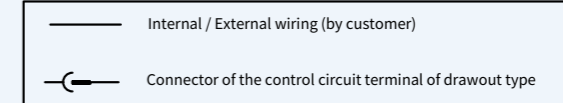

- Note) 1. The diagram is shown with circuit de-energized, all devices open, connected and charged and relays in normal position
- Relay is normal condition and charging type is "OFF-Charging"
 - The standard of auxiliary contact is 3a3b. The auxiliary switch in above diagram is composed of 5a5b. See 48 page for more detail on auxiliary switches.
 - Option
 - Ready to close contact, Trip alarm contact, UVT coil, Fully charged contact, secondary trip coil
 - Cell switch, Temperature module, Voltage module, Remote close-open module, ZCT, ZSI
 - Please consult us for the use of ZSI (Zone selective Interlocking).
 - Refer to the page 33 for the connection of Trip relay and the page 43 for UVT.
 - For connecting RS-485 verify if the polarity is correct
 - Contact configuration for Cell Switch can be changeable if necessary

System diagram

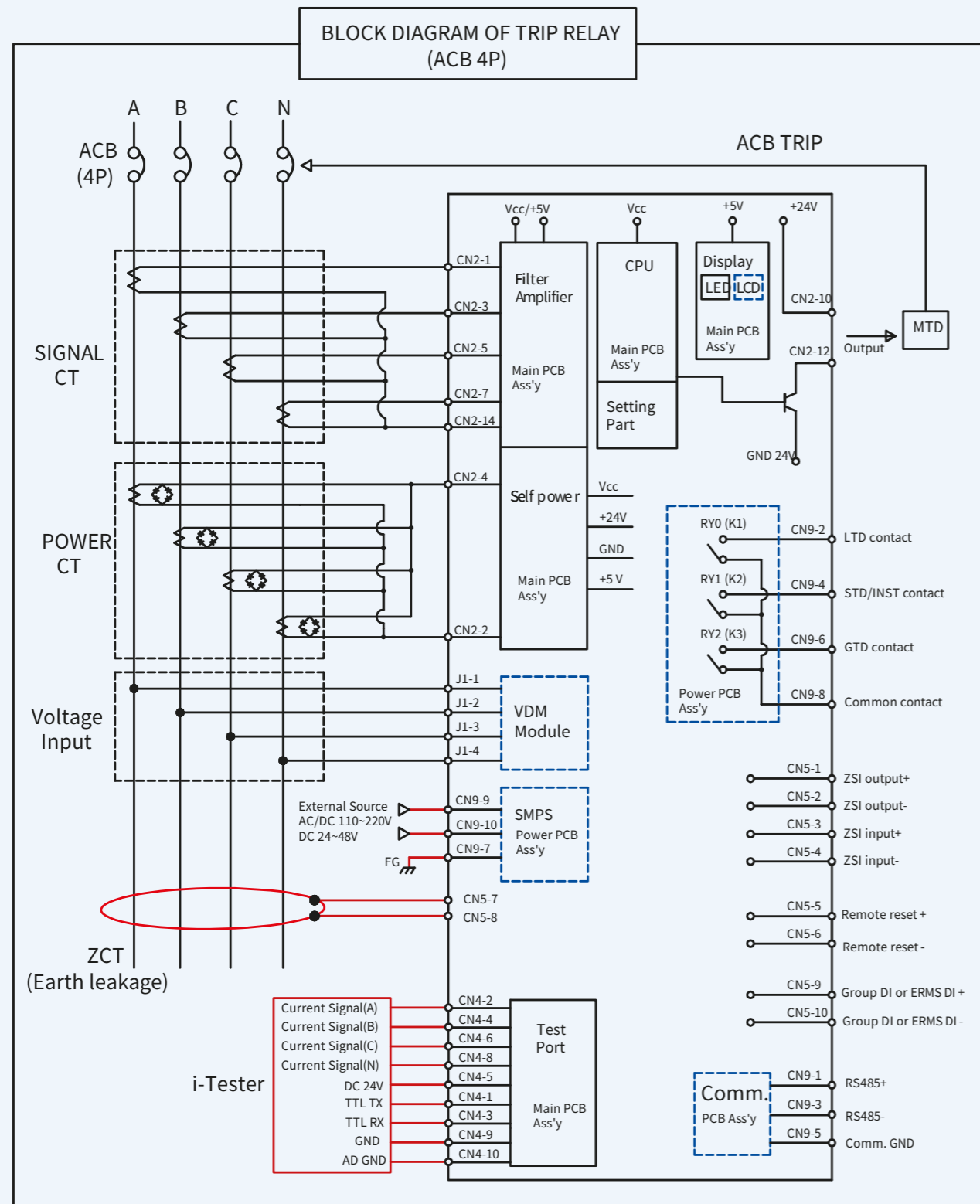

Note: 1. The red display part is for the option order and the user must wire directly.
2. The blue display part must be ordered according to the required specifications when ordering a trip relay.

