

DC MCCB (100~800AF)

- Susol MCCB is suitable for DC application such as Photovoltaic Circuit Breaker, UPS and datacenter
- DC short circuit test tested by VDE
- Higher nominal voltage range up to 1000 VDC
- Rated Current : 16A~800A
- No of Pole: 2/3/4Pole



Rating

Model		TD100	TD160	TS100	TS160	TS250	TS400	TS630	TS800
Frame size (AF)		100	160	100	160	250	400	630	800
Rated current, In (A)		16, 20, 25, 32, 40, 50, 63, 80, 100	100, 125, 160	40, 50, 63, 80, 100	100, 125, 160	125, 160, 200, 250	300, 400	500, 550	700 ^{Note 5)} , 800
No. of poles (Pole)		2, 3, 4	2, 3, 4	2, 3, 4	2, 3, 4	2, 3, 4	2, 3, 4	2, 3, 4	2, 3, 4
Rated operational voltage, Ue (Vdc)	2Pole	500	500	500	500	500	500	500	500
	3Pole	750	750	750	750	750	750	750	750
	4Pole	1000	1000	1000	1000	1000	1000	1000	1000
Rated insulation voltage, Ui (V)	2Pole	800	800	800	800	800	800	800	800
	3Pole	800	800	800	800	800	800	800	800
	4Pole	1000	1000	1000	1000	1000	1000	1000	1000
Rated impulse withstand voltage Uimp (kV)		8	8	8	8	8	8	8	8
Rated ultimate short-circuit breaking capacity, Icu (kA)	Type	H	H	H	H	H	H	H	H
Rated service breaking capacity, Ics [%xIcu]	500VDC (2P)	40	40	40	40	40	40	40	40
	750VDC (3P)	40	40	40	40	40	40	40	40
Trip Unit ^{Note 4)} Function	1000VDC (4P)	40	40	40	40	40	40	40	40
	FTU	●	●	●	●	●	●	●	●
	FMU	●	●	●	●	●	●	●	●
	ATU	-	-	-	●	●	●	●	●

Note)

1. TD100/TD160 is the same Construction Frame.
2. TS100/TS160/TS250 is the same Construction Frame.
3. TS400/TS630 is the same Construction Frame.
4. Trip Unit Function have 3 Types (FTU/FMU/ATU)
 - FTU : Fixed thermal, fixed magnetic unit
 - FMU : Adjustable thermal, fixed magnetic unit
 - ATU : Adjustable thermal, adjustable magnetic unit
 (Not applicable to TS160 100A ATU)
5. 700A is only available for TS800FTU
6. 4Pole type MCCB is 4P4T.

DC Exemplary circuit diagrams

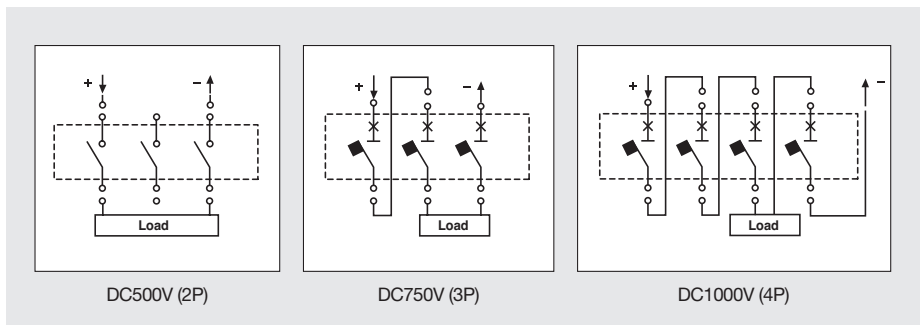

Connection method by DC voltage

Operating voltage (DC)	Center point Connected to earth (A)	One pole connected to earth (B)	Insulated from Earth (C)
~250V	A	A	A
~500V	A	B, C	A
~750V	F	C, E	B
~1000V	F	D	E, F

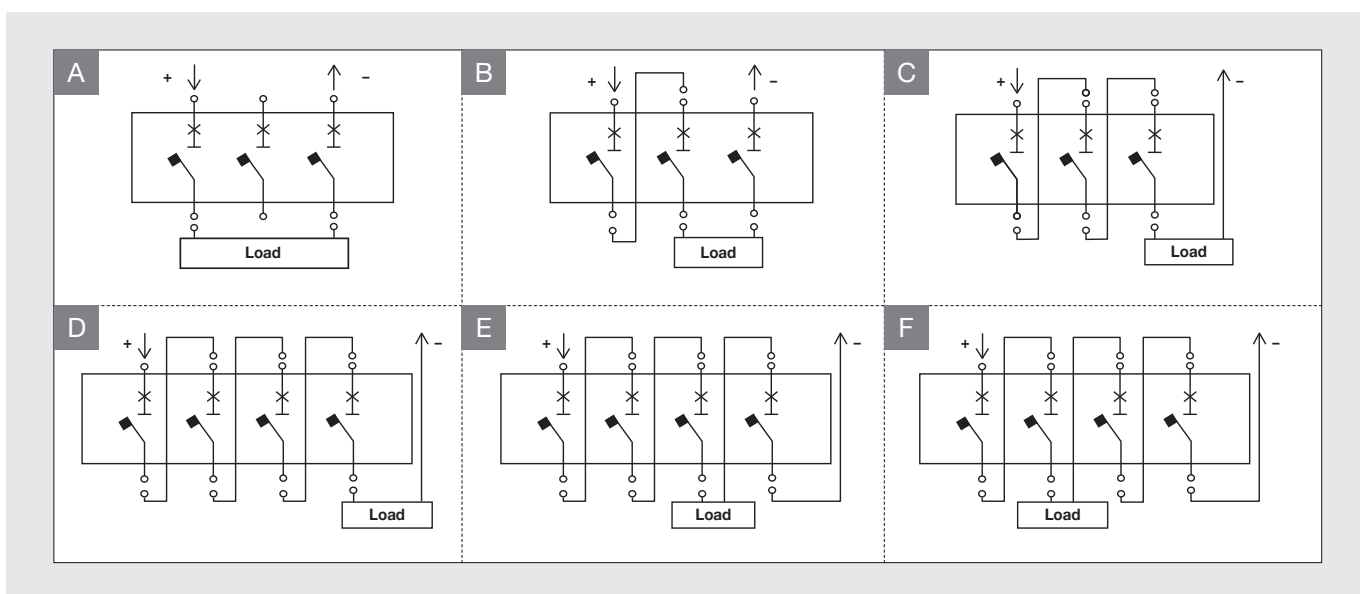

※ Application of 4P4D product when applying 4-pole product

Operating voltage (DC)	Center point Connected to earth (A)	One pole connected to earth (B)	Insulated from Earth (C)
~250V	A1	A1	A1
~500V	A1	B1, C1	A1
~750V	F1	C1, E1	B1
~1000V	F1	D1	E1, F1

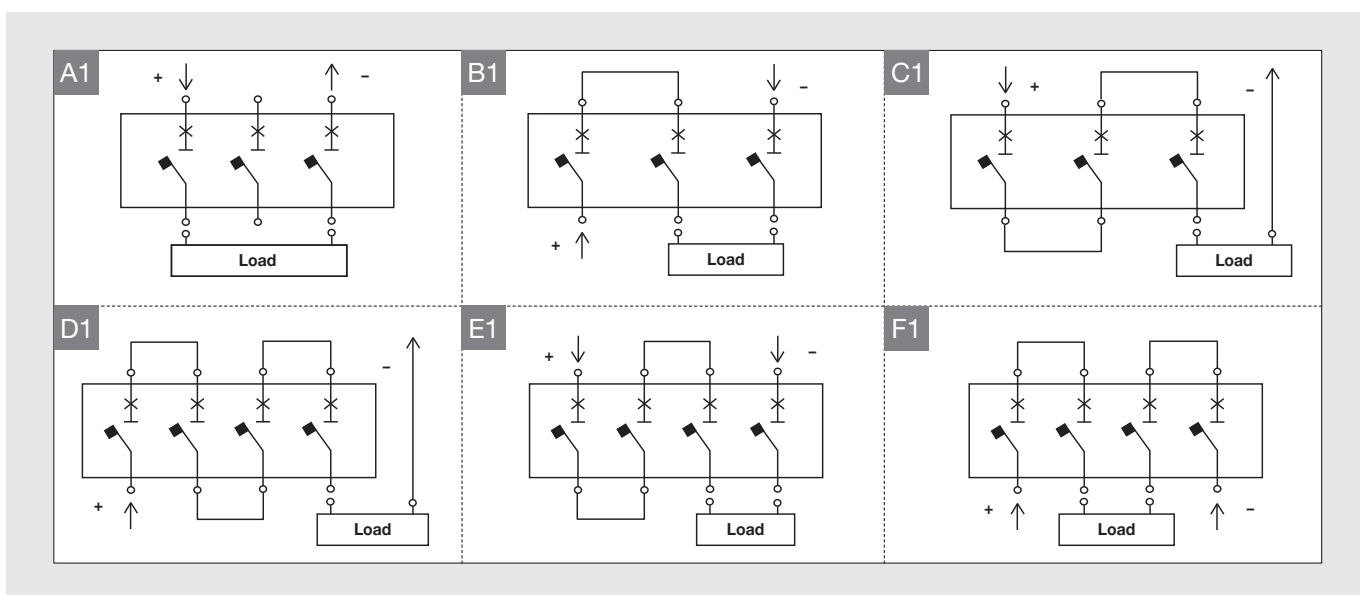

※ Application of 4P4D product when applying 4-pole product

DC MCCB (100~800AF)

Susol MCCB PV up to 800A

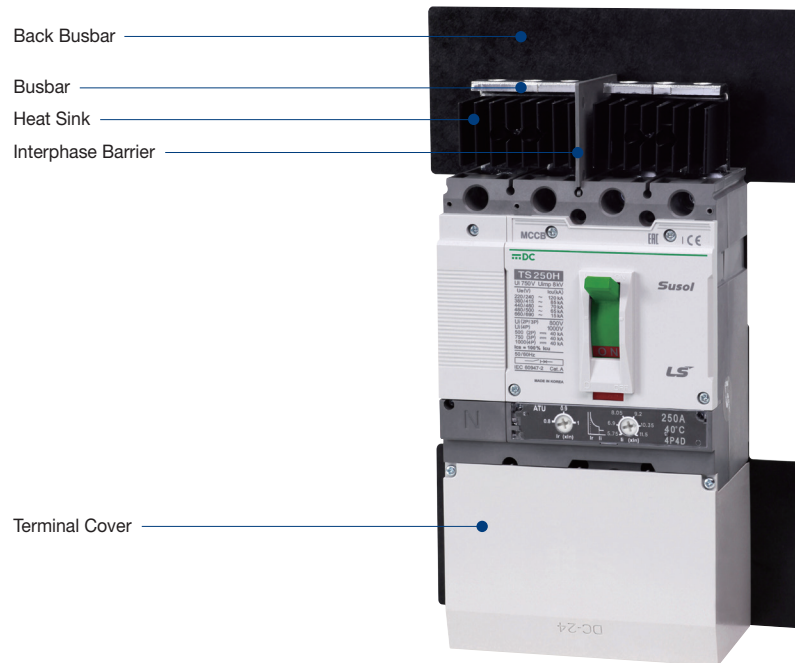

Accessories

Terminal cover



Busbar

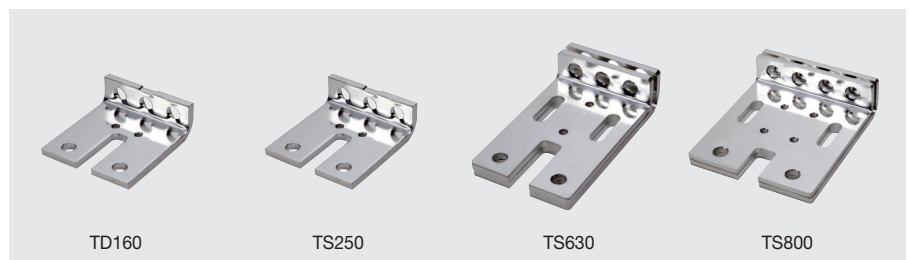

Heatsink

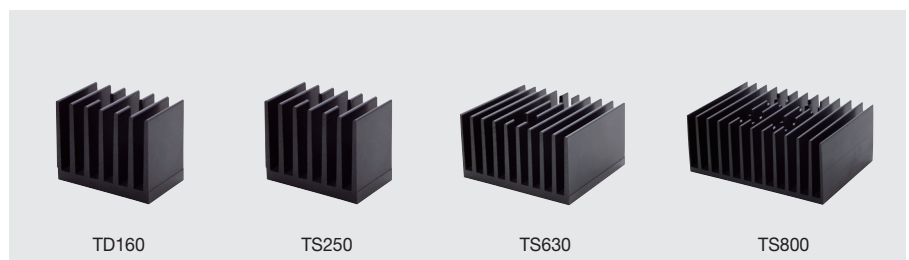

Susol MCCB PV up to 800A

1. Basically, Heat sink and Busbar are optional accessories.
2. A set of Busbar parts is mounted on terminals of the chassis.
3. If Busbar parts are mounted only, it is available to refer to Derating table and if Heat sink parts are mounted additionally, please refer to Rated current table

Derating Table for AF

The following tables are based on the following assumptions;

- Maximum permissible temperature of busbars are 100°C
- T : Temperature around the circuit breaker and its connections

Note) 1. The values presented in the tables are the result of trials and theoretical calculations on the basis of the assumption mentioned above.

2. These tables are intended as an aid in designing connection, however, the actual values must be confirmed by tests on the installation.

Type	Rated Current (A)	Derating Current (A)	Terminal Connection Condition
TD100	16	16	TD160 Busbar 5t
	20	20	
	25	25	
	32	32	
	40	40	
	50	50	
	63	63	
	80	80	
TD160	100	100	TD160 Busbar 5t + Heat Sink
	125	113	
	160	144	
	125	125	
TS100	40	40	TS250 Busbar 5t
	50	50	
	63	63	
	80	80	
TS160	100	100	TS250 Busbar 5t
	125	125	
	160	160	
TS250	125	125	TS250 Busbar 5t + Heat Sink
	160	160	
	200	180	
	250	200	
	200	200	
TS400	250	250	TS630 Busbar Lower & Upper 6t
	300	300	
	400	360	
TS630	400	400	TS630 Busbar Lower & Upper 6t+Heat Sink
	500	400	TS630 Busbar Lower & Upper 6t
	550	440	TS630 Busbar Lower & Upper 6t
	500	500	TS630 Busbar Lower & Upper 6t+Heat Sink
TS800	550	550	TS800 Busbar Lower & Upper 6t
	700 *	630	
	800	640	
	700 *	700	
	800	800	TS800 Busbar Lower & Upper 6t+Heat Sink

Note) 1. * Only available for TS800 FTU

2. Dimension on the connection & busbar.

DC MCCB (100~800AF)

Susol MCCB PV up to 800A

Temperature Derating

Type	Rated Current (A)	Derating Current (A)	Compensated rated current in accordance with ambient temperature (A)																Terminal Connection Condition	
			10℃		20℃		30℃		40℃		45℃		50℃		60℃		70℃			
TD100	16	16	100%	16	100%	16	100%	16	100%	16	100%	16	100%	15	94%	14	88%	13	81%	TD160 Busbar 5t
	20	20	100%	20	100%	20	100%	20	100%	20	100%	19	95%	19	95%	18	90%	18	90%	
	25	25	100%	25	100%	25	100%	25	100%	25	100%	24	96%	23	92%	22	88%	21	84%	
	32	32	100%	32	100%	32	100%	32	100%	32	100%	31	97%	30	94%	29	91%	27	84%	
	40	40	100%	40	100%	40	100%	40	100%	40	100%	39	98%	38	95%	35	88%	33	83%	
	50	50	100%	50	100%	50	100%	50	100%	50	100%	49	98%	47	94%	44	88%	41	82%	
	63	63	100%	63	100%	63	100%	63	100%	63	100%	62	98%	60	95%	56	89%	52	83%	
	80	80	100%	80	100%	80	100%	80	100%	80	100%	78	98%	76	95%	71	89%	66	83%	
TD160	100	100	100%	100	100%	100	100%	100	100%	100	100%	98	98%	95	95%	89	89%	83	83%	TD160 Busbar 5t + Heat Sink
	100	100	100%	100	100%	100	100%	100	100%	100	100%	98	98%	95	95%	89	89%	83	83%	
	125	113	90%	113	90%	113	90%	113	90%	113	90%	109	87%	105	84%	99	79%	92	74%	
	160	144	90%	144	90%	144	90%	144	90%	144	90%	139	87%	135	84%	127	79%	119	74%	
TS100	125	125	100%	125	100%	125	100%	125	100%	125	100%	122	98%	119	95%	111	89%	104	83%	TS250 Busbar 5t
	160	160	100%	160	100%	160	100%	160	100%	160	100%	155	97%	150	94%	141	88%	131	82%	
	40	40	100%	40	100%	40	100%	40	100%	40	100%	39	98%	38	95%	35	88%	33	83%	
	50	50	100%	50	100%	50	100%	50	100%	50	100%	49	98%	47	94%	44	88%	41	82%	
TS160	63	63	100%	63	100%	63	100%	63	100%	63	100%	62	98%	60	95%	56	89%	52	83%	
	80	80	100%	80	100%	80	100%	80	100%	80	100%	78	98%	76	95%	71	89%	66	83%	
	100	100	100%	100	100%	100	100%	100	100%	100	100%	98	98%	95	95%	89	89%	83	83%	
TS250	100	100	100%	100	100%	100	100%	100	100%	100	100%	98	98%	95	95%	89	89%	83	83%	
	125	125	100%	125	100%	125	100%	125	100%	125	100%	122	98%	119	95%	111	89%	104	83%	
	160	160	100%	160	100%	160	100%	160	100%	160	100%	155	97%	150	94%	141	88%	131	82%	
TS250	125	125	100%	125	100%	125	100%	125	100%	125	100%	122	98%	119	95%	111	89%	104	83%	
	160	160	100%	160	100%	160	100%	160	100%	160	100%	155	97%	150	94%	141	88%	131	82%	
	200	180	90%	180	90%	180	90%	180	90%	180	90%	174	87%	168	84%	157	79%	147	74%	
	250	200	80%	200	80%	200	80%	200	80%	200	80%	192	77%	185	74%	172	69%	160	64%	
TS400	200	200	100%	200	100%	200	100%	200	100%	200	100%	196	98%	189	95%	178	89%	166	83%	
	250	250	100%	250	100%	250	100%	250	100%	250	100%	243	97%	236	94%	221	88%	206	82%	
	300	300	100%	300	100%	300	100%	300	100%	300	100%	291	97%	281	94%	264	88%	246	82%	
TS400	400	360	90%	360	90%	360	90%	360	90%	360	90%	348	87%	337	84%	318	80%	305	76%	
	400	400	100%	400	100%	400	100%	400	100%	400	100%	390	98%	378	95%	357	89%	333	83%	
TS630	500	400	80%	400	80%	400	80%	400	80%	400	80%	387	77%	372	74%	347	69%	322	64%	
	550	440	80%	440	80%	440	80%	440	80%	440	80%	426	77%	409	74%	382	69%	354	64%	
	500	500	100%	500	100%	500	100%	500	100%	500	100%	488	98%	476	95%	446	89%	416	83%	
	550	550	100%	550	100%	550	100%	550	100%	550	100%	532	97%	515	94%	486	88%	453	82%	
TS800	700 *	630	90%	630	90%	630	90%	630	90%	630	90%	619	88%	605	86%	584	83%	563	80%	
	800	640	80%	640	80%	640	80%	640	80%	640	80%	619	77%	605	76%	584	73%	563	70%	
	700 *	700	100%	700	100%	700	100%	700	100%	700	100%	684	98%	665	95%	626	89%	584	83%	
	800	800	100%	800	100%	800	100%	800	100%	800	100%	772	97%	748	94%	700	88%	652	82%	

Note) * Only available for TS800 FTU

Susol MCCB PV up to 800A

Warnings when using Susol MCCB for PV applications

The following warning must be kept when using Susol MCCB for PV applications
When violated, it can cause serious damages on relevant products or incur injuries.



Warning

1. Please use wiring in accordance with the diagrams shown below.

Otherwise, usable voltage may be different from the stated requirement.

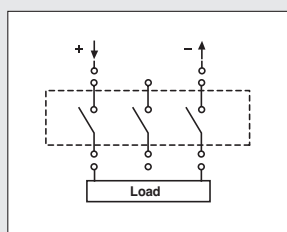

DC500V (2P)

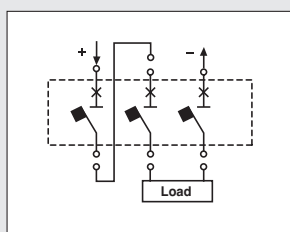

DC750V (3P)

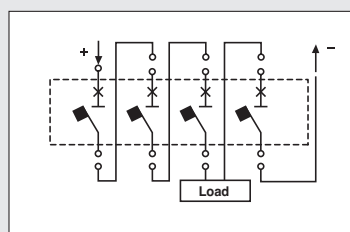

DC1000V (4P)

2. Wire length should be at least 60cm. Shorter wires can cause increase in temperature.
3. De-rated use is highly recommended when designing circuit by using busbar in a manner shown in Figure 1 on the right. If not, it can cause increase in temperature, erroneous trip, damage or fire due to the shortage of heat release(Please refer to the De-rating Table.)
4. Please use thickness and length of busbar in compliance with the specification drawing. When used differently, additional de-rating may be required to release the heat.
5. Use of tin-plated busbar is recommended.
6. Inside of the low voltage panel should not exceed 40°C specified in KS/IEC Standard. Install sun screens or ventilation system if necessary. If violated, it can cause increase in temperature, erroneous trip, damage or fire. Also, additional de-rating is required when the temperature exceeds 40°C.
7. If you have additional questions regarding the application method, please consult with us before the use.

DC MCCB (100~800AF)

Dimensions

TD100, TD160

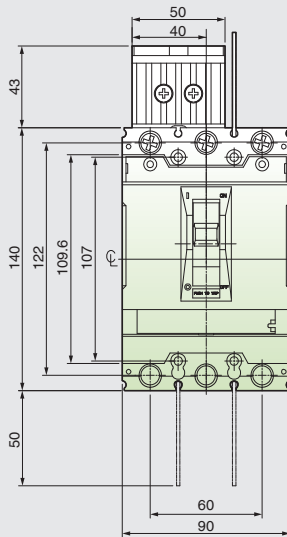

3P

※ R, S Line Common conditions

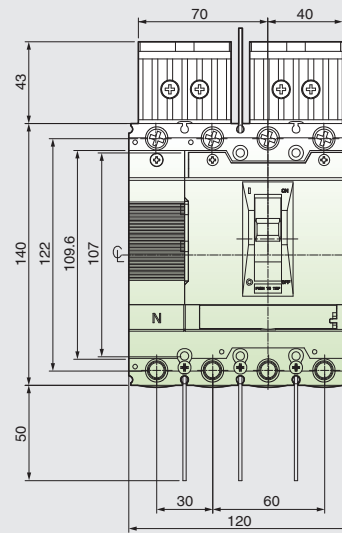

4P (L-type)

TS100, TS160, TS250

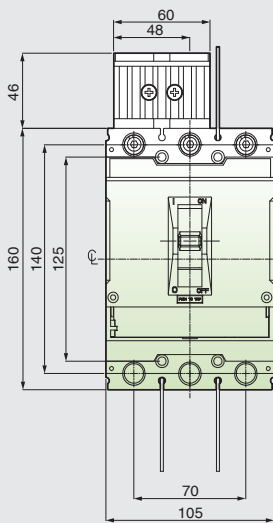

3P

※ R, S Line Common conditions

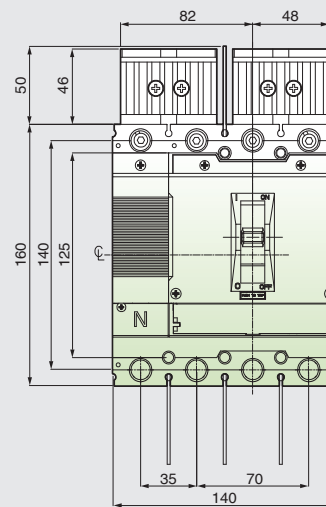

4P (L-type)

※ L-Type and R-Type is symmetric

TS400, TS630

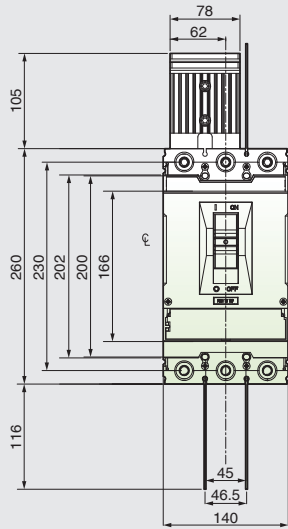

3P

※ R, S Line Common conditions

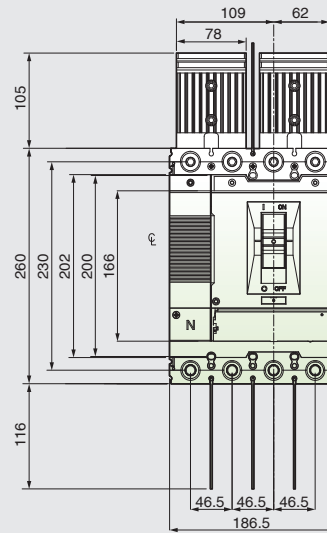

4P (L-type)

※ L-Type and R-Type is symmetric

TS800

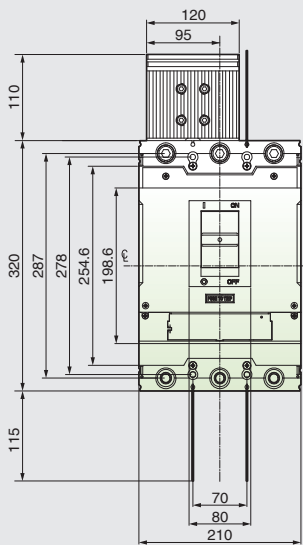

3P

※ R, S Line Common conditions

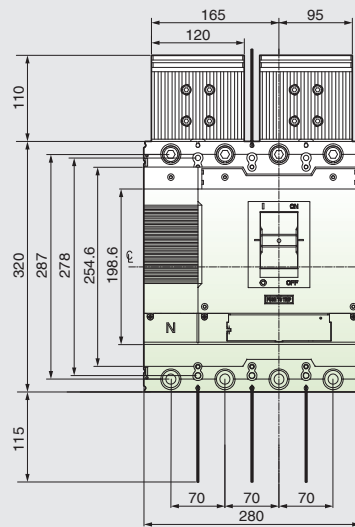

4P (L-type)

※ L-Type and R-Type is symmetric