

# DC MCCB (DC 1000 / 1500V)

## Characteristics

- Applications such as photovoltaic (PV) power generation, UPS and data center.
- Compact size implemented
- Maximum breaking capacity
- Nominal voltage ranges up to 1000/1500Vdc
- Rated current: 63~250A
- No. of poles: 2/4pole



## Rating

AF		250AF			
Type		N-Type	N-Type	H-Type	NA-Type
Model		TSD250N	TSD250N	TSD250H	TSD250NA
Pole		2P	4P		
Rated current, In		63**, 80, 100, 125, 160, 200, 250A			200, 250A
Rated operational voltage, Ue		DC 1000V	DC 1500V		
Rated insulation voltage, Ui		DC 1000V	DC 1500V		
Rated impulse withstand voltage, Uimp		8kV			
Rated short-circuit breaking capacity, Icu		20kA	20kA	50kA	Icw* 3kA, Icm* 3kA
Ics = % Icu		100			-
Category		A			
Type of trip unit		Thermal-Magnetic			-
Current range	Fixed (I <sub>r</sub> )	1 × I <sub>n</sub>			-
Magnetic trip range	Fixed (I <sub>i</sub> )	6 × I <sub>n</sub>			-
Life cycle (time)	Mechanical	10,000			
	Electrical	2,000			1,000
Dimension (W×H×D, mm)		76 × 170 × 92	140 × 170 × 92		
Standards		IEC/EN60947-2, GB14048.2			IEC60947-3 & Annex D(For PV) GB/T14048.3
Certification		CCC, CB			

\* Icw: Rated short-circuit withstand current(kA), 1s

Icm: Rated short-circuit making capacity(kA)

\*\* 63A Magnetic trip range: 8×I<sub>n</sub>

## Temperature derating

Type	Rated Current (A)		Derating Current (A)		Compensated rated current in accordance with ambient temperature (A)								Terminal Connection		
	2P	4P	2P	4P	40°C		45°C		50°C		60°C			70°C	
TSD250	63	63	100%	100%	63	100%	62	98%	60	95%	56	89%	52	83%	TSD250 BUSBAR 5T
	80	80	100%	100%	80	100%	78	98%	76	95%	71	89%	66	83%	
	100	100	100%	100%	100	100%	98	98%	95	95%	89	89%	83	83%	
	125	125	100%	100%	125	100%	122	98%	119	95%	111	89%	104	83%	
	160	160	100%	100%	160	100%	155	97%	150	94%	141	88%	131	82%	
	200	200	100%	100%	200	100%	196	98%	190	95%	178	89%	166	83%	
	250	250	100%	100%	250	100%	243	97%	235	94%	220	88%	205	82%	

\* Load-side terminal cover using derating current applied to 90%

## Altitude derating

Altitude (m)	Ue (Vdc)			250AF
	2P	4P	Compensation constant	
2000	1000V	1500V	1.00	100%
3000	870V	1300V	0.87	98%
4000	770V	1150V	0.77	93%
5000	670V	1000V	0.67	90%

\* Exclusive codes required for MOP order

## Exclusive external accessories

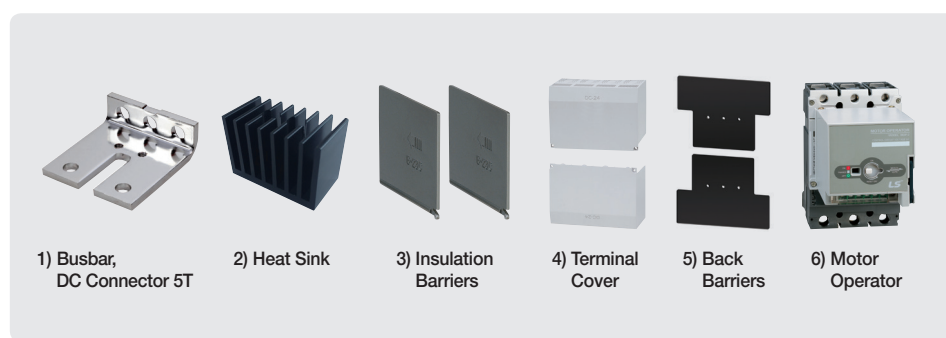

## Possible configuration of electrical auxiliaries



UVT



SHT



AX

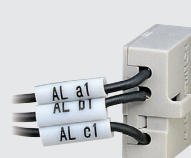

AL

**Maximum possibilities**

Phase	Accessory	TSD250
R (Left)	AX	1
	AL	1
	SHT, UVT	1
T (Right)	AX	1
	AL	-

Note) 1. The internal accessories are assembled together with the product, so be careful when ordering.  
2. SHT / UVT can not be used simultaneously

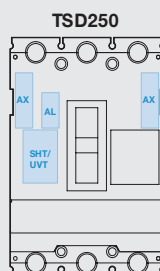

TSD250

# DC MCCB (DC 1000 / 1500V)

## Wiring diagram

### 1. Unground system

4Pole

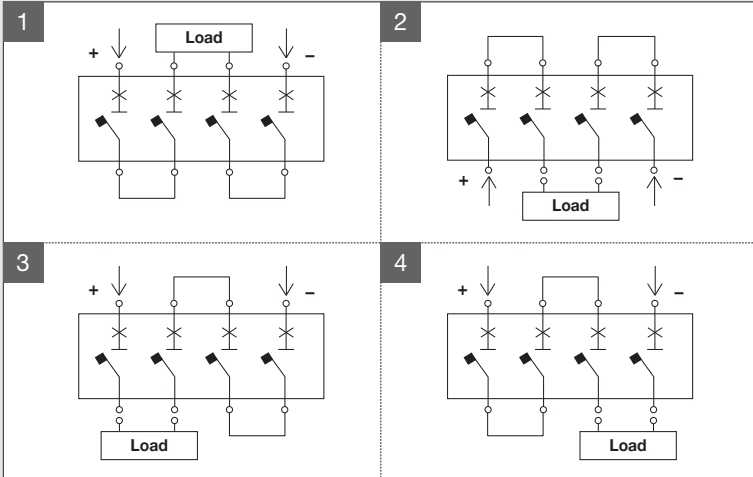

2Pole

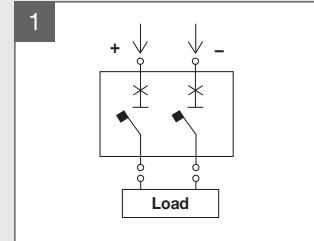

### 2. Grounded system

4Pole

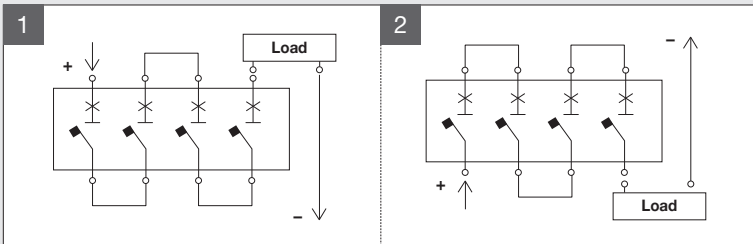

2Pole

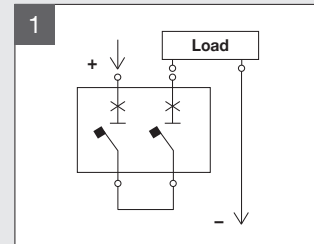

## Characteristic curve

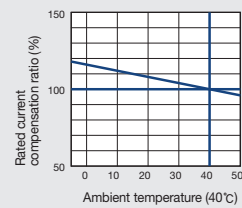
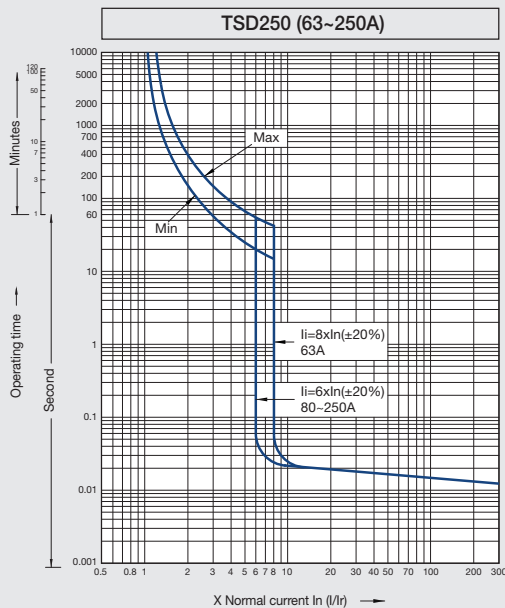

## Product installation standards

### 1. By insulation and separation distance

- One side (30mm or more),
- Up & down (121mm or more)
- Between products (60mm or more)

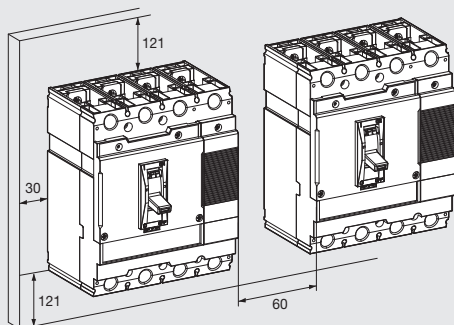

### 2. Close mounting

- Using barrier between phases

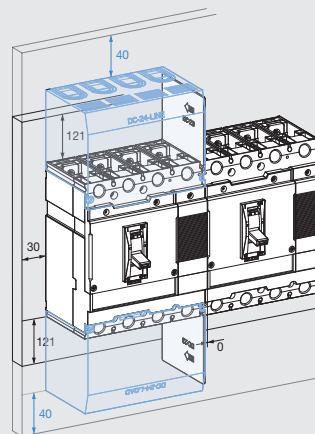

## Dimensions

### 4Pole

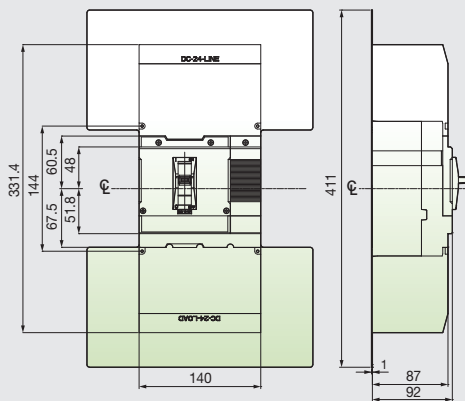
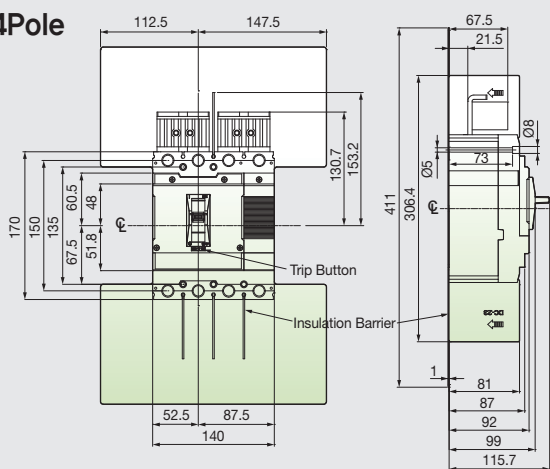

#### Terminal details

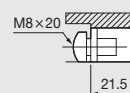
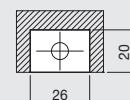

#### Connecting

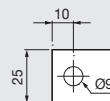

### 2Pole

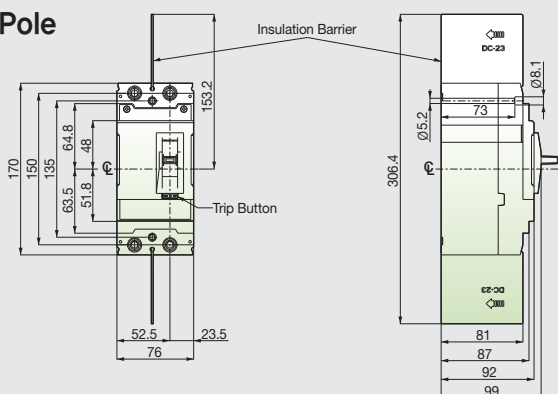

#### Panel drilling

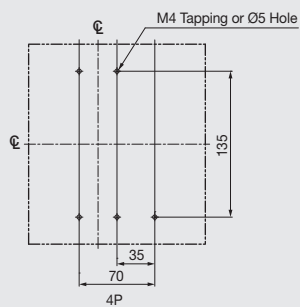

#### Front panel cutting

