

DMPi Series

Intelligent Digital Motor Protection Relays



Revolutionary development of motor protection relays

Complete motor protection is realized
with real time data processing and high precision.





DMPi Series

Intelligent Digital Motor Protection Relays

- Definite/Inverse time option and various protection methods
- Storage of failure causes
- Separated display part using cables
- MODBUS communication, 4~20mA DC output
- Operating time displayed for each model



Contents

- 04 A list of standard models
- 05 Product characteristics
- 09 Rated specifications & model numbering system
- 10 Operation & setting method
- 19 Terminal configuration / Wiring & cable connection
- 25 Dimensions



A list of standard models

A list of standard models

Rated current	Connection method	Model No.	Over-current	Stall/ Locked rotor	Phase fail current	Phase un-balance	Reverse phase	Under current	Ground fault	Instant short circuit	Remarks
0.5~6A	Terminal type	DMP06i-S	●	●	●	●	●	●	-	-	<ul style="list-style-type: none"> If there is the function of RS485 communication, 'M' is appended to its type name. If there is the function of 4~20mA DC output, 'A' is appended to its type name. RS485 communication function and 4~20mA DC output function are not supported at the same time.
		DMP06i-SZ, SB	●	●	●	●	●	●	●	-	
		DMP06i-SI	●	●	●	●	●	●	-	●	
	Penetrated type	DMP06i-SZI, SBI ^{Note1}	●	●	●	●	●	●	●	●	
		DMP06i-T	●	●	●	●	●	●	-	-	
		DMP06i-TZ, TB	●	●	●	●	●	●	●	-	
		DMP06i-TI	●	●	●	●	●	●	-	●	
DMP06i-TZI, TBI ^{Note1}	●	●	●	●	●	●	●	●			
5~65A	Terminal type	DMP65i-S	●	●	●	●	●	●	-	-	
		DMP65i-SZ, SB	●	●	●	●	●	●	●	-	
		DMP65i-SI	●	●	●	●	●	●	-	●	
	Penetrated type	DMP65i-SZI, SBI ^{Note1}	●	●	●	●	●	●	●	●	
		DMP65i-T	●	●	●	●	●	●	-	-	
		DMP65i-TZ, TB	●	●	●	●	●	●	●	-	
		DMP65i-TI	●	●	●	●	●	●	-	●	
DMP65i-TZI, TBI ^{Note1}	●	●	●	●	●	●	●	●			

Note) 1. It is possible to set up ground fault and instantaneous trip contacts separately.

Convenience



Integrated Digital Motor Protection Relay based on MCU(Microprocessor Control Unit)

Real Time Processing and High Precision are implemented.



Applicable to inverter circuits

It may be applied to the secondary inverter control circuit with its outstanding resistance to harmonic noise. Permissible frequency range is 10~200Hz. When the percentage of harmonic is more than 30%, a harmonic filter is installed. (However, the ground fault protection function should be switched off.)



Function to store the cause(s) of failure / Fault

Up to 5 motor failure events may be saved in the system, so that the failure history can be easily identified.



Up to 5 motor failure events may be saved in the system, so that the failure history can be easily identified.

The display part is separated and attached to the front panel, so that information on current/operating time and setup can be viewed without taking out the unit. With the separated display, motor protection can be performed.



Communication function

General-purpose RS485/MODBUS communication mode is offered for various system and communication network configurations. Models with analog current signal (4~20mA DC) output are compatible with systems that uses the existing TD (Transducer).



A wide range of reset functions

Manual/Automatic/Electrical reset functions are provided for user convenience.



Date information display

When a failure occurs, the date and time of failure occurrence are saved in the system to accurately identify the date of motor failure.



Password setting

When changing the set values, a password must be inserted.



Total operating time and operating time setting

When the predefined operating time has elapsed, related information is displayed so that operators may replace the motor bearing and check the refueling cycle.



Terminal/Penetrated types are shared for application in various installation environments

Terminal blocks are detachable, which makes them applied to various installation environments.

Reliability



Thermal Inverse Time, Inverse Time and Definite Time Modes

According to user's needs, the motor can be protected in the inverse time mode or definite time mode.



Three-phase digital ampere-meter

Three-phase current is displayed in cycle at intervals of 2 seconds for operators to check the motor state.



Various protection elements and additional functions

Single/3-phase is optional, and output contact as well as the operating time can be set. Free Voltage power connection (AC/D85~260V) is possible with ZCT built-in option.



High Reliability

The current relay error is reduced from 5% to 3% and the minimum sensible current is lowered from 70% to 30% of the minimum rating. Phase fail/phase unbalance protection relay correction and delay time can be set.



Inverse time characteristic good for motor protection

Thanks to the inverse time characteristic in which a running time is determined by a size of overcurrent, the equipment is excellent at motor protection.

Product characteristics

Protection functions

Over current. Overload

Considering the start-up time of a motor and based on 600% of the rated current, operating time is set by 1sec unit ranging from 1 to 60 seconds to establish an overload characteristic curve (Class 1~60). When a definite time characteristic is chosen, overcurrent is detected from the set operating delay time (D-Time) regardless of the quantity of heat generated from the motor. Then, Trip is generated when overcurrent continues, exceeding the operating time (O-Time).

Stall / Locked rotor

It is a function to prevent burning caused by locked rotor, startup failure and startup delay. When the level of load current increases due to overheating and overcurrent during operation or when the load torque exceeds the motor torque, such failure is detected to break the related circuits.

Phase fail / Phase unbalance

When phase fail occurs, a motor may not start to operate and the motor under operation will stop owing to the lack of torque or reverse phase current will continue to flow, generating heat. DMPi calculates the unbalance of three-phase current and when it reaches 100%, it operates at 3sec as phase fail. It can be set for tripping at 5sec when the phase unbalance is within 10~90%.

*Delay time may be set within the range of 0~200sec so that it does not function upon startup.

Reverse phase

It is a function to prevent reversing of a motor. The phase difference of three-phase current is compared for operation within 0.1~1.0sec when the phase sequence has changed. Reverse phase is checked only upon motor startup.

Under current protection

This equipment is mainly used to monitor no-load status caused by the separation or damage of the drive shaft of a motor, or to protect the idle rotation (no-load) status of pump. It is possible to set up 30~70% of rated current. At the time of third second, it runs.

Ground fault

Ground fault leakage current is detected to prevent ground faults arising from electric leakage and secondary accidents (Phase faults and electric shock accidents). Current sensitivity and operating time are set differently according to the grounded system or purpose of protection. Current sensitivity can be set within the range of 30mA~3A and the operating time within the range of 0.05~5.0sec.

*Delay time may be set within the range of 0~200sec so that it does not function upon startup, and built-in ZCT is provided according to the Type.

Instance

It is a function to protect a motor from short-circuit current. It operates within 50ms when fault current of more than 500~1500% is generated. Delay time may be set within the range of 0~200sec so that it does not function upon startup.

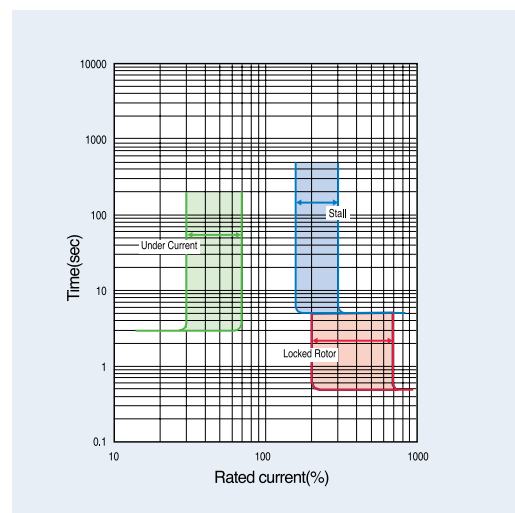
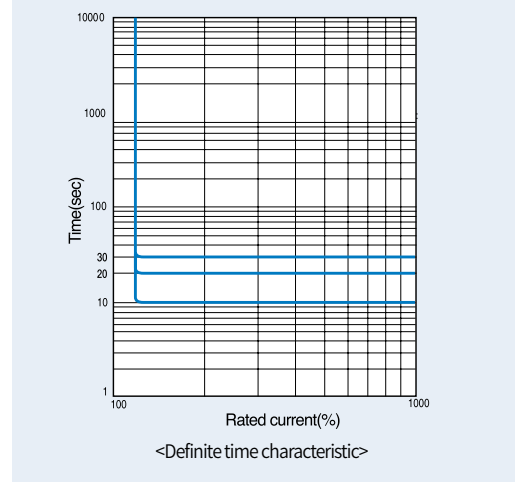
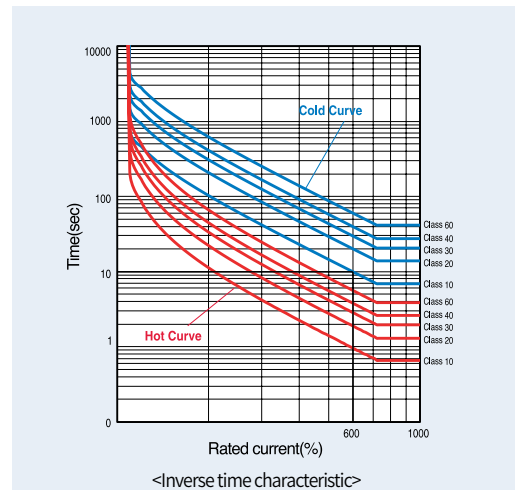

Communication function

MODBUS specifications

Communication code	1 ~ 247
Communication speed	9600, 19200, 38400, 57600 bps
Communication parity	None, Even, Odd
Fixed to 1bit	1bit
Communication data swap	Limited to float, long data of Off / On (0x04 (Read input registers))

Block diagram of communication system

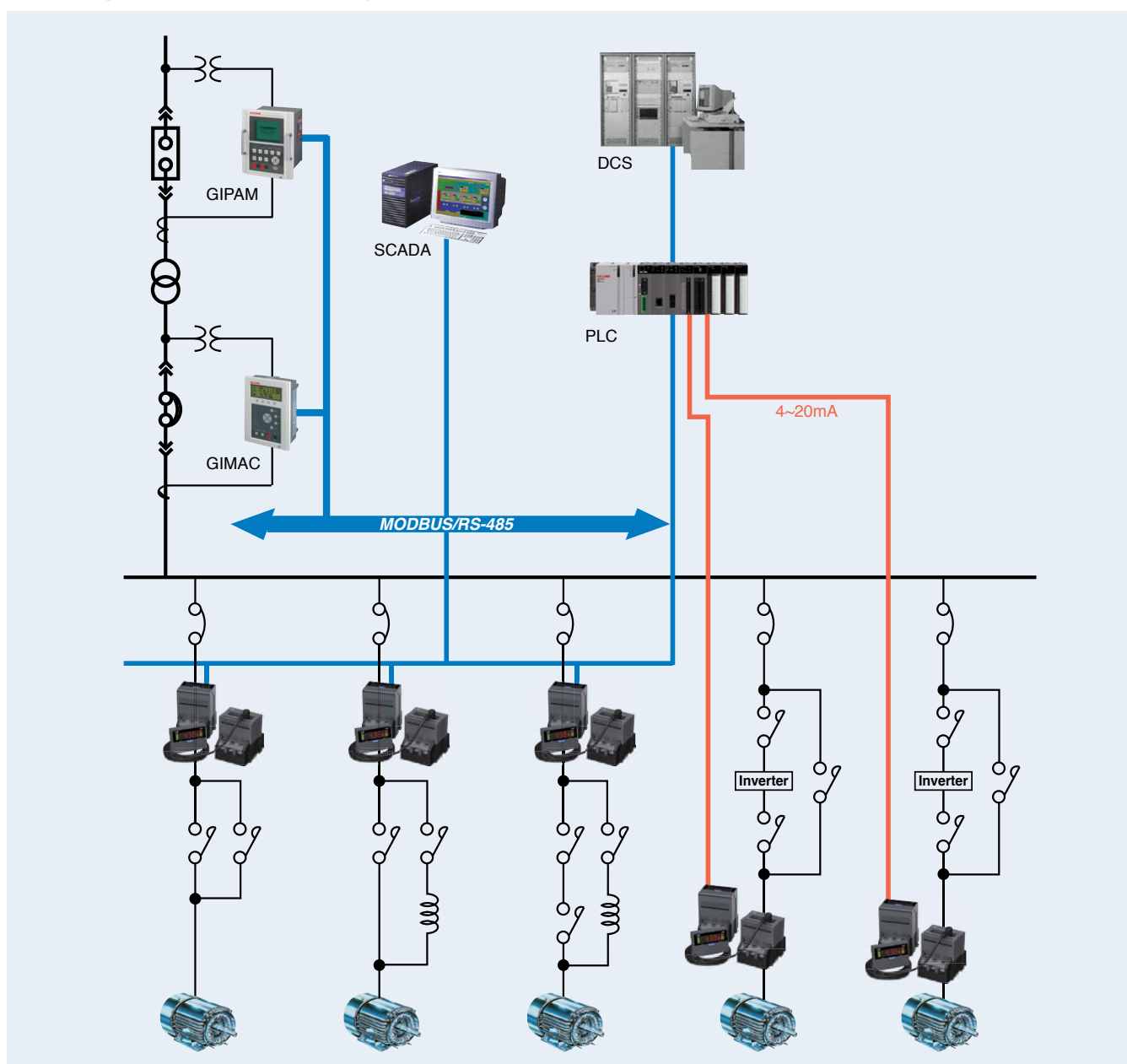

Product characteristics

Analog (4~20mA) output function

Specifications

- The measured values of current for the maximum phase among the measured values of three-phase current are converted into DC 4~20mA and the measured values of current can be displayed with a digital meter in the distance.
- 20mA output setting: 0.5~6A or 5~65A

Note) 1. At the setting mode of 0.5~6A, the level of current is measured from 0.15A, so 0A is measured when less than 0.15A and the output value becomes 4mA. (When it is 0.15A, >4mA is actually measured.)

2. Measurement error based on temperature changes: $\pm 0.15\%/^{\circ}\text{C}$ (Based on the room temperature of 25°C)

- Motor stop state: 4mA
- Setting value exceeding the rating: 20mA
- Load: Within 500Ω

Note) The allowable load of cables should be within 500Ω and the cables for shielding should be used considering the resistance of the received meta (Generally 250Ω) and line resistance.

$$\begin{aligned}\text{Output current} &= \frac{(\text{Upper Limit} - \text{Lower limit})}{\text{TD Setting value}} \times \text{Load current} + 4\text{mA} \\ &= \frac{16\text{mA}}{\text{TD setting value}} \times \text{Load current} + 4\text{mA}\end{aligned}$$

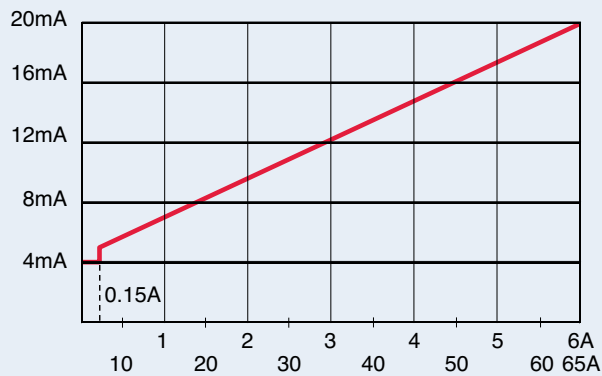

Analog output when output setting is 6A (65A)

Rated specifications

Connection method		Penetrated / Terminal type
Protection functions		Overcurrent, phase fail, phase unbalance, stall, locked rotor, reverse phase, ground fault (Type option) Instance (Type option)
Connection method		Penetrated / Terminal type
Operating time characteristics		Thermal heat build-up inverse time / Non-thermal heat build-up inverse time / Definite time
Rated current		0.5~6A/5~65A (Rating option upon placing an order)
Display		4 digit, 7-Segment
Operating power		AC/DC 85~260V (50Hz/60Hz)
Reset method	Automatic	1~20min (only for overcurrent)
	Manual	(Electrical reset)
Installation / Mounting method		Display can be installed separately, 35mm DIN rail / Screw installation
Tolerance	Current	±3%
	Time	±5%
	4~20mA output	±5%
Time setting	Startup delay	1~200sec
	Operation delay	1~60sec
Aux. contact	Composition	3-SPST (Power supply 1a1b, instantaneous operation 1a) ^{Note1)}
	Capacity	3A/250VAC Resistive Load
	Contact minimum load	100mA / 6VDC : (95-996, 97-98) 10mA / 5VDC (07-08)
ZCT Input	External	200mA/100mV (Exclusive ZCT) ^{Note2)}
	Built-in	Support (Separate connection unnecessary) ^{Note2)}
Service environment	Service temperature	-20°C ~ 60°C
	Storage temperature	-30°C ~ 70°C
	Relative humidity	within 80% RH, no condensation
Insulation resistance		100MΩ/500VDC
Lightning impulse voltage		1.2X50us 5kV Prototype waveform supply
Fast transient		2kV/1Min
Power consumption		Below 2W

Note 1. See No. 21 to 23 of A-Group in Setting menu. If single phase is set, the device measures R/S/T phase. In HMI, the maximum phase of three phases is displayed without any indication of phase.

2. It is used when zero current detection type is selected.

3. This product is used to protect a low-voltage motor with 1000V or less.

Model numbering system

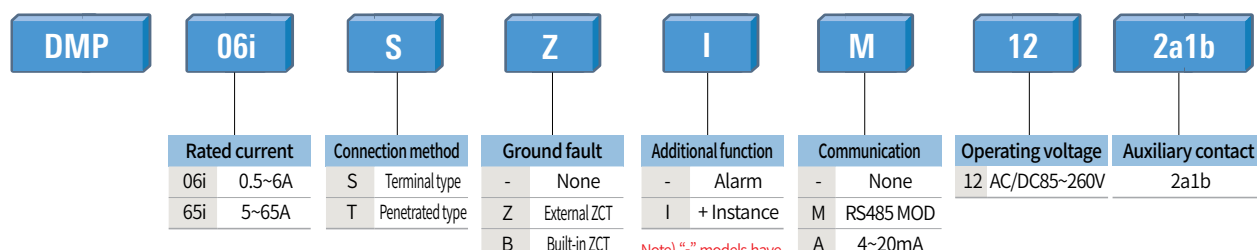











Note) “-” models have Alarm + Operating Time + Failure History storage functions as the default.

“i” models have an additional instance protection function.

Operation & setting method

Display explanation



Type	Item	Description	Remarks
Display	 R S T N	Display of R, S, T, or N phase	If fixed, flickering
	 4 digit 7-segment	Display of a variety of information (numbers, text)	
	 BAR GRAPH	Display of load factor (%) 50% ~ 120%	If 120% or more, flickering
	 C	Display of communication status (C)	In communication, flickering
	 %	Load factor (%) display unit	Depending on lighting status
	 A	Current (A) display unit	Display of information
Button	 TEST/RESET	Access TEST Mode and Release TRIP, Go to the top of menu	
	 ENTER	Access Menu and Change & Save Setting Values	
	 UP	Go to Items (Measurement Value, Group, Menu, Parameter Increase)	
	 DOWN	Go to Items (Measurement Value, Group, Menu, Parameter Decrease)	

Operation & setting method

Before starting the motor, the following setting should be completed.

1. Check the test / Reset button.

- 1) First, check whether the connection method is appropriate. (Refer to the section on the connection method.)
- 2) Press the Test/Reset button once. 'Test' will be shown on the display and the device will be tripped.
- 3) When the Test/Reset button is pressed one more time during the device Trip, the display will be switched to the operating mode and the device will be reset for normal operation.

Note) To prevent trip failures, the system is designed to prevent operation of the Test/Reset button when the motor is running.

Note) Setup and setting values may change during the motor operation. Thus, please be cautious.

2. Setting method

- 1) Press Enter from the current display screen, and **A-Gr** will appear on the screen. Use the Up or Down button to choose a group that you want and press Enter to display a menu on the chosen group. Press the Test/Reset button again to return to the current display screen.
- 2) The first menu will be displayed in relation to the selected group. Use the Up or Down button to choose a menu that you want and press Enter. The screen on setting values will be displayed. Press the Test/Reset button to display the group selection mode

Note) Start menu may vary according to the model specifications.

- 3) If you press the Up or Down button from the screen on setting values, **P-99** will appear on the screen. Here, use the Up or Down button to change the value to P-00 and press Enter to return to the screen on setting values. The setting value will flicker and can be changed with the Up or Down button.

After setting the value, press Enter. The value will be saved and the flicking values will be switched off.

- 4) With it switched on, press Enter to proceed to the next menu or press the Test/Reset button to go back to the previous menu. Related menus can be set with the same procedure.

Note) Password insertion (P-00) is performed only once when changing the setting values. When no changes are made for 10 minutes, it can be re-inserted and changed.

Note) With it switched on, press Enter to proceed to the next menu or press the Test/Reset button to go back to the previous menu. Related menus can be set with the same procedure.

Note) When power is supplied for the first time or after power failure, the date information must be inserted at b-gr 4,S-d.

3. How to check the failure history

- 1) Press the "Down + Up" buttons at the same time and the latest cause of a failure will be displayed on the screen. **! - -**

Note) When there is no failure history, it will be displayed as "non".

- 2) When saving more than 2 failure cases, use the Up or Down button to check any Event that you want. Then press Enter from the Event display to view the details on the failure causes.

Note) There may be differences in details displayed according to the failure cause.

Note) 5 causes of Trip in total are saved and when it exceeds 5 cases, the previous data are deleted for storage.

4. Operating time setting

- 1) B group **35rL** is used for time setting (10~8,760). After the set operating time has elapsed, Trip state will be displayed with OrH. When A group **22AL** is set with OrH, 07-08 contact will be output.

5. Total operating time and operating time check

- 1) Total operating time can be checked from B group, **lt r t** which is displayed in the following order: day/hour/minute.
- 2) Operating time can be checked from B group, **2r - t** which is displayed in the following order: hour/minute.

Note) When no current flows in the motor, the operating time will be displayed as 0.

Note) The total operating time is saved every 10 minutes. When turned off, any value less than 10 minutes will be reset.

6. Heat quantity reset (The motor's heat quantity is reset by force to switch to the cold mode.)

- 1) When the operating characteristics of A Group 2.CHA are set in the thermal heat build-up mode (th)
- 2) When the Test/Reset key is pressed under overload trip to return and then a motor is driven right away, the motor will be hot. Thus, trip is immediately performed.
- 3) On the other hand, when the Enter + Test / Reset keys are pressed simultaneously under overcurrent trip to return and then a motor is driven right away, the motor will be cold. Thus, trip will be executed after the set time.

Operation & setting method

7. Three-phase current circulation display

- 1) Three-phase operating current that automatically circulates is displayed at intervals of 2 seconds.
- 2) To view a specific phase on the circulation display, press Enter in relation to such phase for 2 seconds. The phase will flicker and be displayed.
- 3) If you want to display the circulating three-phase current again, use the Up or Down key to cancel the state for circulation display.

Menu configuration

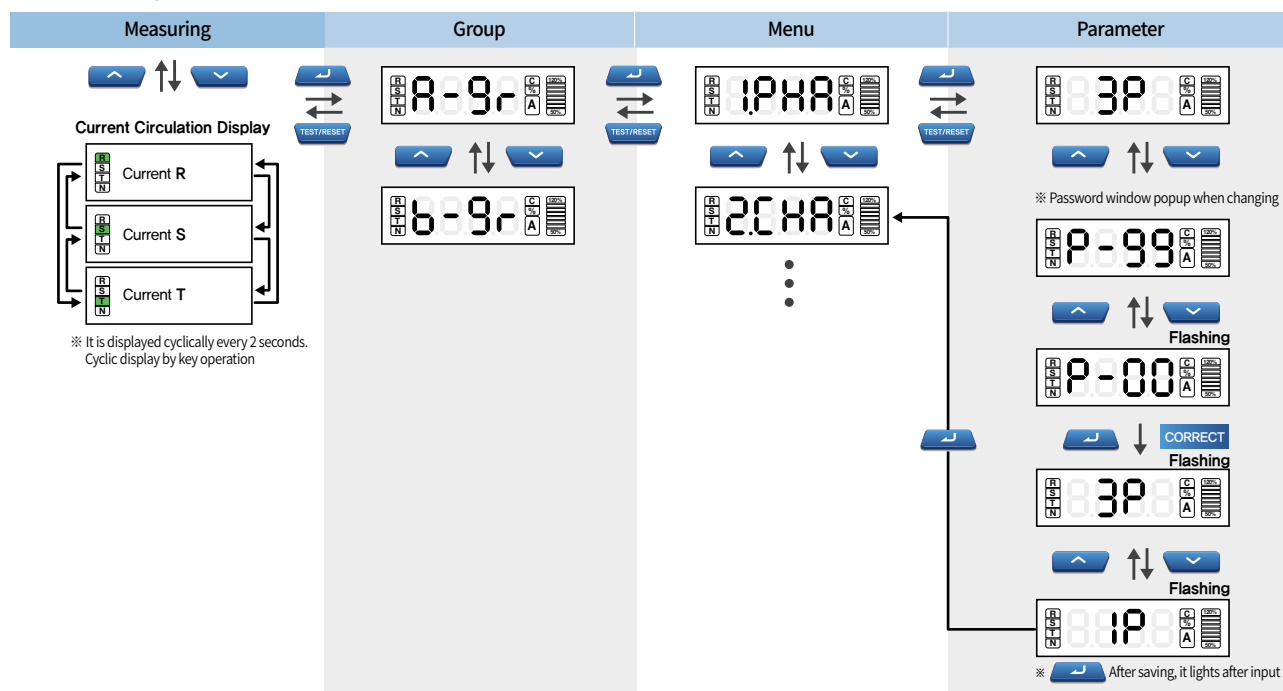

Information display

Display information	Failure state	Additional display information	Remarks
<code>0-L</code>	Overcurrent	Fault current (R-phase, S-phase and T-phase) Load factor, time	Operates at the set time
<code>Loc</code>	Lock	Fault current (R-phase, S-phase and T-phase) Load factor, time	Operates within 0.5sec
<code>StL</code>	Stall	Fault current (R-phase, S-phase and T-phase) Load factor, time	Operates in 3sec
<code>P-F</code>	Phase fail	Fault current (R-phase, S-phase and T-phase) Load factor, time	Operates in 3sec (Delay time setting needed)
<code>P-U</code>	Phase unbalance	R-phase, S-phase and T-phase, Unbalance factor, time	Operates in 5 sec (Delay time setting needed)
<code>r-P</code>	Reverse phase	Time	Operates at the set time
<code>U-C</code>	Under current	Fault current (R-phase, S-phase and T-phase) Load factor, time	Operates in 3sec
<code>g-F</code>	Ground fault (ZCT)	Fault current (R-phase, S-phase and T-phase) N-phase, time	Operates at the set time (Delay time setting needed)
<code>Sho</code>	Instance	Fault current (R-phase, S-phase and T-phase) Load factor, time	Operate within 50ms (Delay time setting needed)
Alarm information	<code>OrH</code>	Set operating time has elapsed	An alarm is displayed if a cumulative running time exceeds a set running time
Self-diagnosis information	<code>LInE</code>	Display communication error	When a communication error occurs between the display and body, please contact our office with the alarm maintained.
	<code>EErr</code>	External memory error	When there is an error in the backup memory, please contact our office with the alarm maintained.

A-Group

Group	Display	Setting item	Setting value(Display value)	Single phase Note1)	Default	Remarks Note4)
A	1P _H A	Single phase/Three-phase	1P/3P	1P	3P	
	2C _H A	Operating characteristic (Overcurrent protection)	dEF/n-th/th Note2)	0	n-th	
	30-t	Operating time	1~60sec	0	60	
	4d-t	Delay time	1~200sec	0	200	Displayed upon 2.CHA dEFT setting
	5r-C	Rated current(6, 65)	0.5~6A/5~65A	0	6/65	Maximum rated current display (06i: 6A, 65i: 65A)
	6Ct-r	CT Ratio	0.25/0.5/1~200 Note3)	0	1	
	7L _o c	LOCK	Off/200~800%	0	Off	
	8S _t L	STALL	Off/150~500%	0	Off	
	9P-F	Phase fail(100%)	On/Off	-	On	
	10P _d	Phase fail delay time	0~200	-	0	Displayed upon 9.P-F setting
	11P _U	Phase unbalance	Off/10~90%	-	Off	
	12U _d	Phase unbalance delay time	0~200	-	0	Displayed upon 10.PU setting
	13r _P	Phase unbalance delay time	Off/On Note5)	-	Off	
	14r _t	Phase unbalance delay time	0.1~1.0	-	0.1	Displayed upon 13.rP setting
	15U _C	Phase unbalance delay time	Off/30~90%	0	Off	
	16g _F	Phase unbalance delay time	Off/0.03/0.05/0.1~3.0A	0	Off	
	17g _t	Phase unbalance delay time	0.05, 0.1~5.0sec	0	1	Displayed upon 16.gF setting
	18g _d	Phase unbalance delay time	0~200sec	0	200	Displayed upon 16.gF setting
	19I _C	Phase unbalance delay time	Off/500~1500% Note6)	0	Off	
	20I _d	Phase unbalance delay time	0~200	0	0	Displayed upon 19.IC setting
	21a ₅	Phase unbalance delay time	2a, 1a1b, 2b	0	1a1b	
	22A _L	Phase unbalance delay time	I-tp, I-AL, ALo, U-C, OrH, g-F Note7)	0	I-tp	
	23A _r	Phase unbalance delay time	On/60~110%	0	On	Displayed upon 22.AL Alo setting

Note) 1. When setting A group 1.PHA menu with 1P, restricted setting with limited functions can be made.

2. Operating characteristic th refers to the thermal heat build-up inverse time characteristic and n-th refers to the non-thermal heat build-up inverse time characteristic. When th is used, the quantity of heat generated will be reset as power is turned off. Thus, please pay attention to it.

3. CT Ratio is fixed to 1 for 65A Type model.

4. Some menus will not be displayed depending on the function setting for each model.

5. Reverse phase will be detected for only 1.5 seconds after load is activated. It is recommended to set as Off for a motor not in normal-reverse operation.

6. In case of 'Instance', the maximum setting value may change according to the rated current setting.

7. For models with ground fault and instance protection functions, the ground fault and instantaneous trip contacts may be separately set for use.

Operation & setting method

The output conditions of 95-96, 97-98 output contacts depending on the setting of A group 21.cS are as described below.

21.cS Setting	Output conditions	Contact output type	
		95-96	97-98
1a1b	Normal operation	NC ^{Note)}	NO ^{Note)}
	Ground fault / Short circuit	O ^{Note)}	C ^{Note)}
	Other failures, such as overcurrent, phase fail and reverse phase other than the ground fault	O	C
2a	Normal operation	NO	NO
	Ground fault/Short circuit	O	C
	Other failures, such as overcurrent, phase fail and reverse phase other than the ground fault	C	O
2b	Normal operation	NC	NC
	Ground fault/Short circuit	C	O
	Other failures, such as overcurrent, phase fail and reverse phase other than the ground fault	O	C

Note) NC: Normal Close, NO: Normal Open, O: Open, C: Close

The output conditions of 07-08 output contacts depending on the setting of A group 22.AL are as described below.

23.Ar setting	Output conditions	Alarm output type	
		Motor operation	07-08
I-tp	Momentary current detected	Motor stop	C
I-AL	Momentary current detected	State maintained	C
U-C	Current flow below the set low current detected	State maintained	C
OrH	Output exceeding the set operating time	State maintained	C
g-F	Ground fault detection	Motor stop	C
ALo	Conforming to the 23.Ar setting described below		
23.Ar setting	ALo setting from menu No.22	Motor operation	07-08
On	Current flow exceeding the measured minimum current value detected ^{Note)}	State maintained	C
60~110%	Current flow exceeding the setting value	State maintained	C

Note) The measured minimum current value is 30% of the minimum rated current value (0.15A for 0.6i type; 1.5A for 65i type)

B-Group

Group	Display	Setting item	Setting value (Display value)	Single phase ^{Note1)}	Default	Remarks ^{Note4)}
B	1t-r-t	Total operating time	0~9999day/0~23Time/0~59min	O	-	
	2r-t	Operating time	0~9999 Time/0~59min	O	-	
	3s-r-t	Operating time setting	Off/10~8760	O	Off	
	4s-d	Date setting ^{Note2)}	2017~2100yea/1~12month/1~31day/ 0~23hour/0~59min	O	2017.07.01 00:00	
	5A-r	Automatic reset ^{Note3)}	Off/1~20min	O	Off	
	6Ad-r	Communication network address	1~247	O	247	Displayed only for M485 model
	7bPS	Communication speed	9.6k/19.2k/38.4k/56.7k	O	9.6k	
	8S-P	Swap On/Off	On/Off	O	Off	
	9P-r	Parity setting	nonE/odd/EUEn	O	nonE	
6t-d	20mA setting	0.5~6/5~65	O	6/65	Displayed only for A420 model	

Note) 1. It can be set even when A group 1.PHA is set with the single phase (1P).

2. When power is supplied for the first time or after power failure, date must be set. For date setting, month, day, hour and minute should be respectively set for complete setting. (After date setting, it is saved every 10 minutes. When power is supplied again after power failure, the date before such power failure will be saved.)

3. Automatic reset is restricted for overcurrent trip.

4. Menus vary according to the model. (refer to the remarks)

Phase setting

This is a function to set current input either as single or three-phase.



The DMPi main screen display (0.00A)



1. Press Enter from the main screen. (A-gr)



2. Press Enter from the A-gr screen. (1. PHR)



3. Press Enter from the PHR screen and the initial value 3P will be displayed.



4. Here, use the Up / Down key to display P-99 from the screen. Change it into P-00 with the Up/Down key and press Enter. You are now ready for setting. (Only required for initial setting)



5. The set value flickers. Use the Up / Down key to display 'phase' that is applicable depending on the motor specifications (1P: single-phase; 3P: three-phase). Then, press Enter to save the setting. (1P)

- ① Choose either 1P or 3P; the default is 3P
- ② When 1P is selected, A group items such as "9.P-F", "10.Pd", "11.PU", "12.Ud", "13.rP" and "14.rt" are excluded from the setting menu.



6. Press Test / Reset to return to the display screen.

Rated current setting

This is a function to set a rated current.



The DMPi main screen display (0.00A)



1. Press Enter from the main screen. (A-gr)



2. Press Enter from the A-gr screen. (1. PHR)



3. Press the Up-key menu 3 or 4 times from the PHR screen. (5.r-C)



4. Press Enter from the 5.r-C screen and the initial value 6.0A will be displayed.



5. Here, use the Up / Down key to set the value as 0.5~6.0A. Then, press Enter to save the setting. [Note1\) \(6.0→5.4A\)](#)

- ① 6A model: Set by 0.1A unit ranging from 0.5A to 6A (the default is 6.0A)
- ② 65A model: Set by 1A unit ranging from 5A to 65A (the default is 65A)

6. Press Test / Reset to return to the display screen.

[Note 1\)](#) Upon initial setting, P-99 is displayed on the screen. Here, use the Up / Down key to change it into P-00 and press Enter. You are now ready for setting.

Operation & setting method

Overcurrent operating characteristic setting

This is a function to set the operating characteristic of the overcurrent element.



The DMPi main screen display (0.00A)



1. Press Enter from the main screen. (A-gr)



2. Press Enter from the A-gr screen. (1. PHR)



3. Press the Up-key menu once from the PHR screen. (2.CHA)



4. Press Enter from the 2.CHA screen to display 'n-th' (initial value).

5. The set value flickers. Use the Up / Down key to display the set value. [Note1](#)



6. Press Enter for dEF setting.

- ① dEF (definite time), n-th (non-thermal heat build-up inverse time) or th (thermal heat build-up inverse time)
- ② When set as 'n-th' or 'th', "4.d-t" of the A group items is excluded from the setting menu.

7. Press Test / Reset to return to the display screen.

[Note 1](#)) Upon initial setting, P-99 is displayed on the screen. Here, use the Up / Down key to change it into P-00 and press Enter. You are now ready for setting.

Overcurrent operating time setting

This is a function to set the operating time of the overcurrent element.



The DMPi main screen display (0.00A)



1. Press Enter from the main screen. (A-gr)



2. Press Enter from the A-gr screen. (1. PHR)



3. Press the Up-key menu twice from the PHR screen. (3.O-t)



4. Press Enter and the initial value 60sec will be displayed.

5. Use the Up / Down key to display the set value on the screen. [Note1](#)



6. Press Enter to set as 30sec. (60 → 30 sec)

7. Press Test / Reset to return to the display screen.

[Note 1](#)) Upon initial setting, P-99 is displayed on the screen. Here, use the Up / Down key to change it into P-00 and press Enter. You are now ready for setting.

Overcurrent delay time setting

This menu is displayed only when the overcurrent operating characteristic is set as dEF (definite time).



The DMPi main screen display (0.00A)



1. Press Enter from the main screen. (A-gr)



2. Press Enter from the A-gr screen. (1. PHR)



3. Press the Up-key menu 3 times from the 1.PHR screen. (4.d-t)



4. Press Enter from the 4.d-t screen and the initial value 200 will be displayed.

5. Use the Up/Down key to display the set value on the screen. **Note1)**



6. Press Enter to set as 100sec. (200 → 100sec)

① Set by 1sec unit ranging from 1 sec to 200sec; the default is 200sec.

② When the overcurrent operating characteristic is set as 'n-th' or 'th', it is excluded from the setting menu.

7. Press Test/Reset to return to the display screen.

Note 1) Upon initial setting, P-99 is displayed on the screen. Here, use the Up/Down key to change it into P-00 and press Enter. You are now ready for setting.

Ground fault operating value setting

This is a function to set the operating value of ground fault.



The DMPi main screen display (0.00A)



1. Press Enter from the main screen. (A-gr)



2. Press Enter from the A-gr screen. (1. PHR)



3. Press the Up-key menu from the 1.PHR screen to proceed to 16.gF.

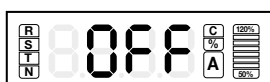

4. Press Enter from the 16.gF screen and the initial value OFF will be displayed.

5. Here, use the Up/Down key to set the value. Press Enter to save the setting. **Note1)** (OFF → 0.1A)

① Set by 0.1A unit ranging from 0.1A to 3.0A; or OFF, 0.03A, or 0.05A. (the default is OFF)

6. Press Test / Reset to return to the display screen.

Note 1) Upon initial setting, P-99 is displayed on the screen. Here, use the Up/Down key to change it into P-00 and press Enter. You are now ready for setting.

Operation & setting method

Ground fault operating time setting

This is a function to set the operating time of ground fault.



The DMPi main screen display (0.00A)



1. Press Enter from the main screen. (A-gr)



2. Press Enter from the A-gr screen. (1. PHR)



3. Press the Up-key menu from the 1.PHR screen to proceed to 17.gt



4. Press Enter from the 17.gt screen and the initial value 1.0sec will be displayed.



5. Here, use the Up / Down key to set the value. Press Enter to save the setting. **Note1)(1.0→0.1sec)**
① Set by 0.1sec unit ranging from 0.1sec to 5.0sec; the default value is 1.0sec.

6. Press Test / Reset to return to the display screen.

Note 1) Upon initial setting, P-99 is displayed on the screen. Here, use the Up/Down key to change it into P-00 and press Enter. You are now ready for setting.

Note 2) When the operating value of ground fault protection (16.gF) is set as OFF, it is excluded from the setting menu.

Ground fault delay time setting

This is a function to set time for blocking operation of the ground fault element upon motor activation.



The DMPi main screen display (0.00A)



1. Press Enter from the main screen. (A-gr)



2. Press Enter from the A-gr screen. (1. PHR)



3. Press the Up-key menu from the 1.PHR screen to proceed to 18.gd.



4. Press Enter from the 18.gd screen and the initial value 200sec will be displayed.



5. Here, use the Up / Down key to set the value. Press Enter to save the setting. **Note1)(200→100sec)**
① Set by 1sec unit ranging from 0sec to 200sec; the default value is 200sec.

6. Press Test / Reset to return to the display screen.

Note 1) Upon initial setting, P-99 is displayed on the screen. Here, use the Up/Down key to change it into P-00 and press Enter. You are now ready for setting.

Note 2) When the operating value of ground fault protection (16.gF) is set as OFF, it is excluded from the setting menu.

Terminal configuration

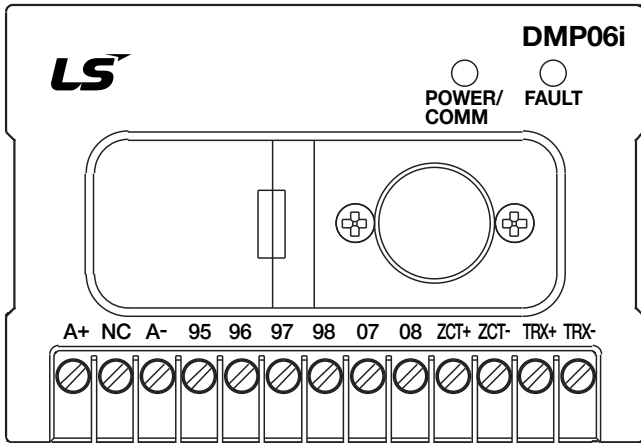

Engrave	Description
A+, A-	Input terminal for operation power
95-96	When the power is ON (NC contact output)
97-98	When the power is ON (NO contact output)
07-08	Alarm contact output terminal
ZCT+, ZCT-	ZCT output connection
TRX+, TRX- 420+, 420-	RS485 connect or 4~20mA output

DMPi-B built-in ground fault protection type (1a1b)

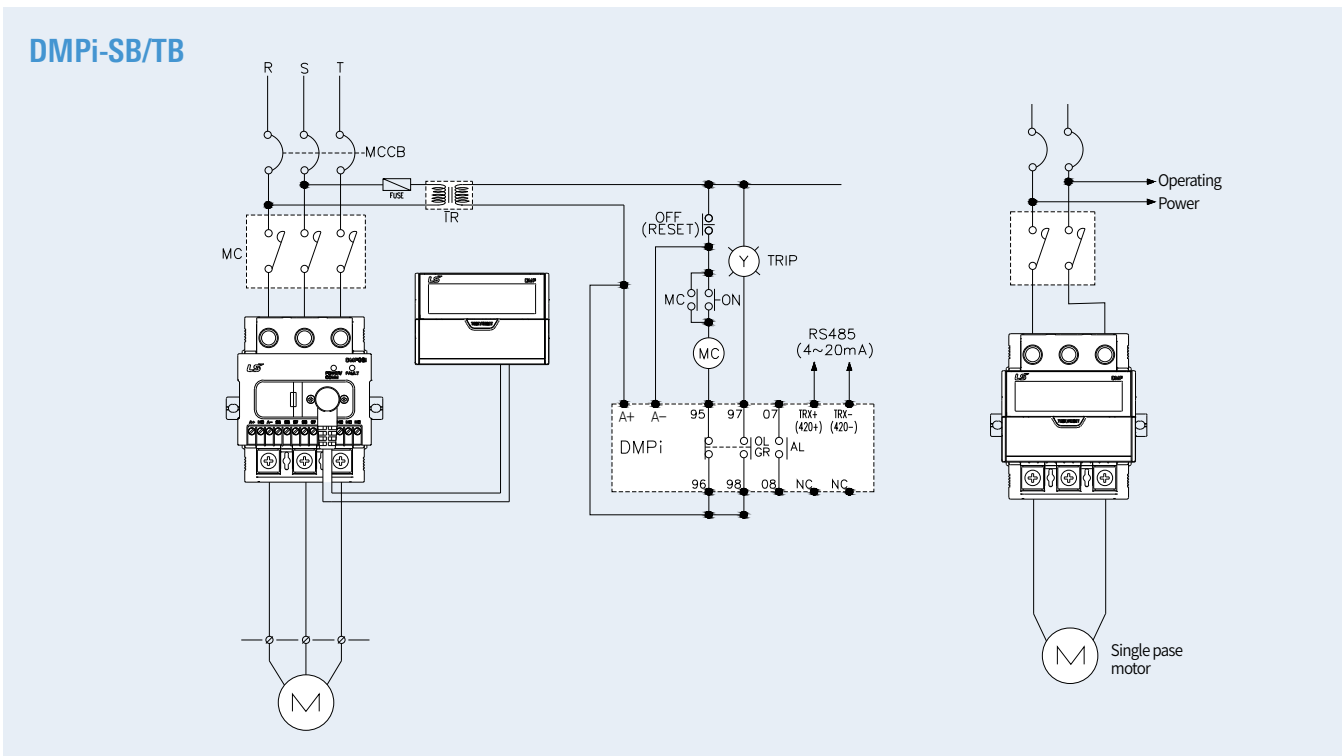

Terminal configuration / Wiring & cable connection

DMPi-B built-in ground fault protection type (2a)

DMPi-SB / TB

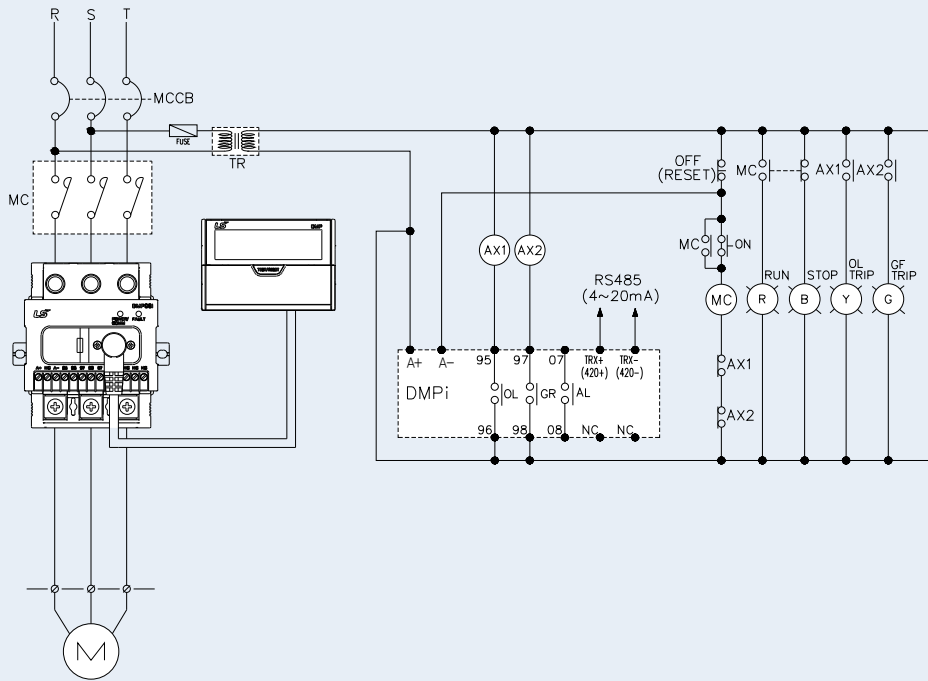

DMPi-B built-in ground fault protection type (2b)

DMPi-SB / TB

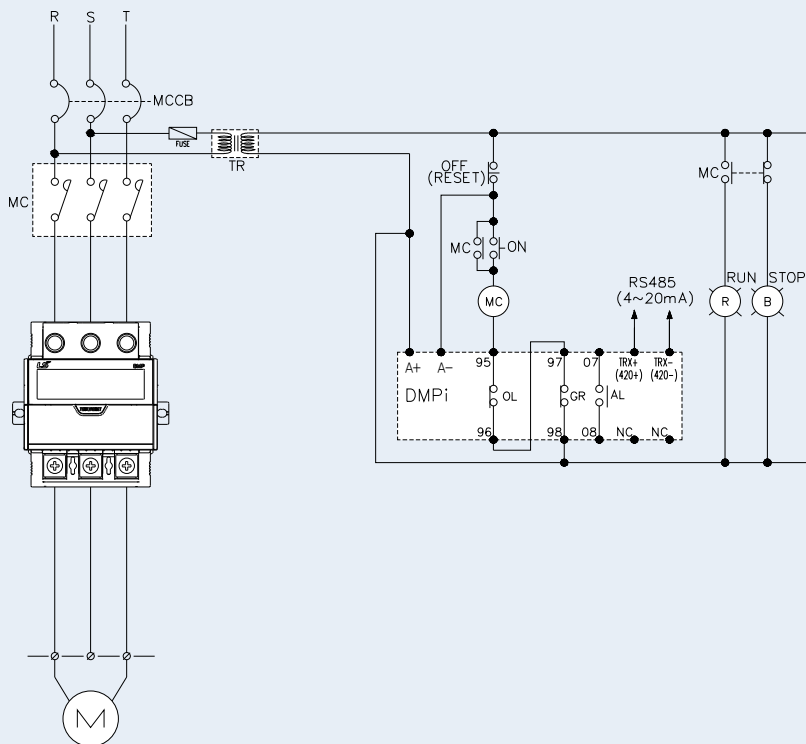

DMPi-SBI / TBI, SI / TI built-in instant short-circuit protection type (1a1b)

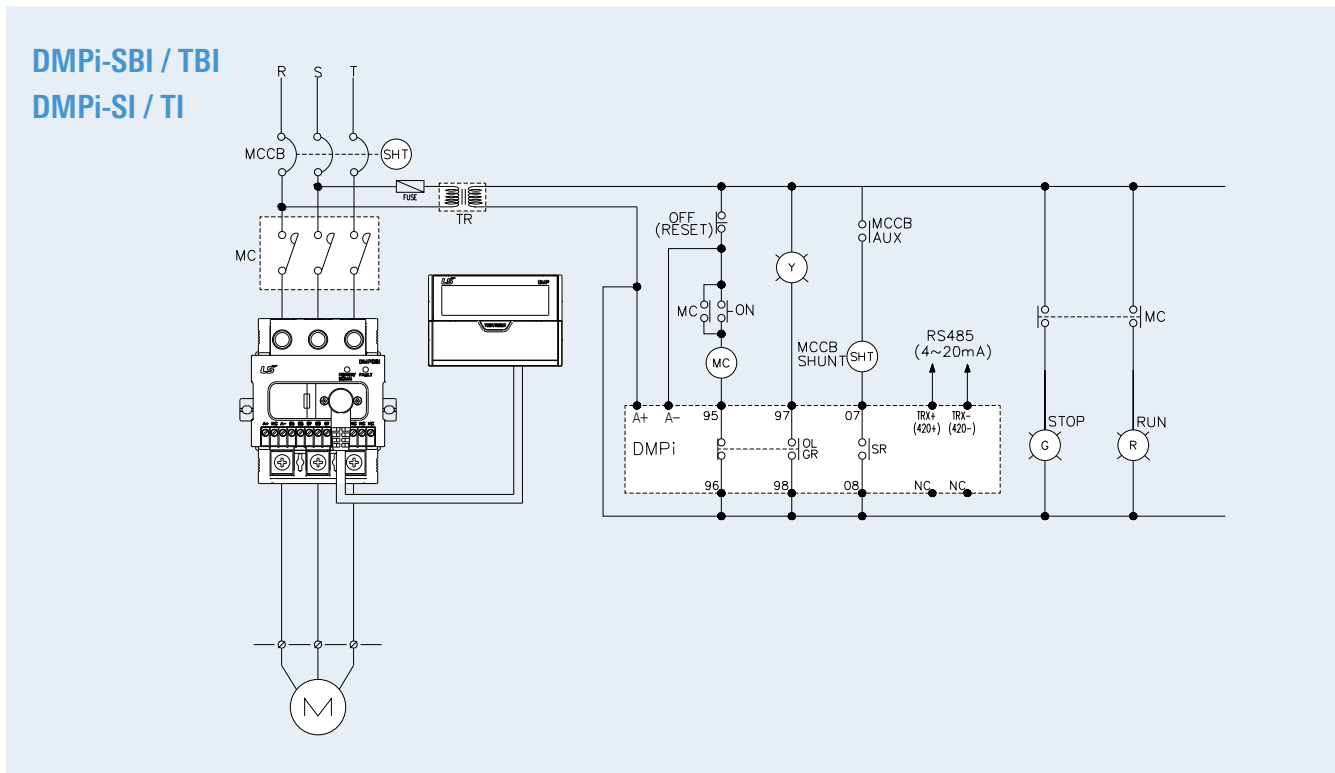

DMPi-SZ / TZ external ground fault protection type (1a1b)

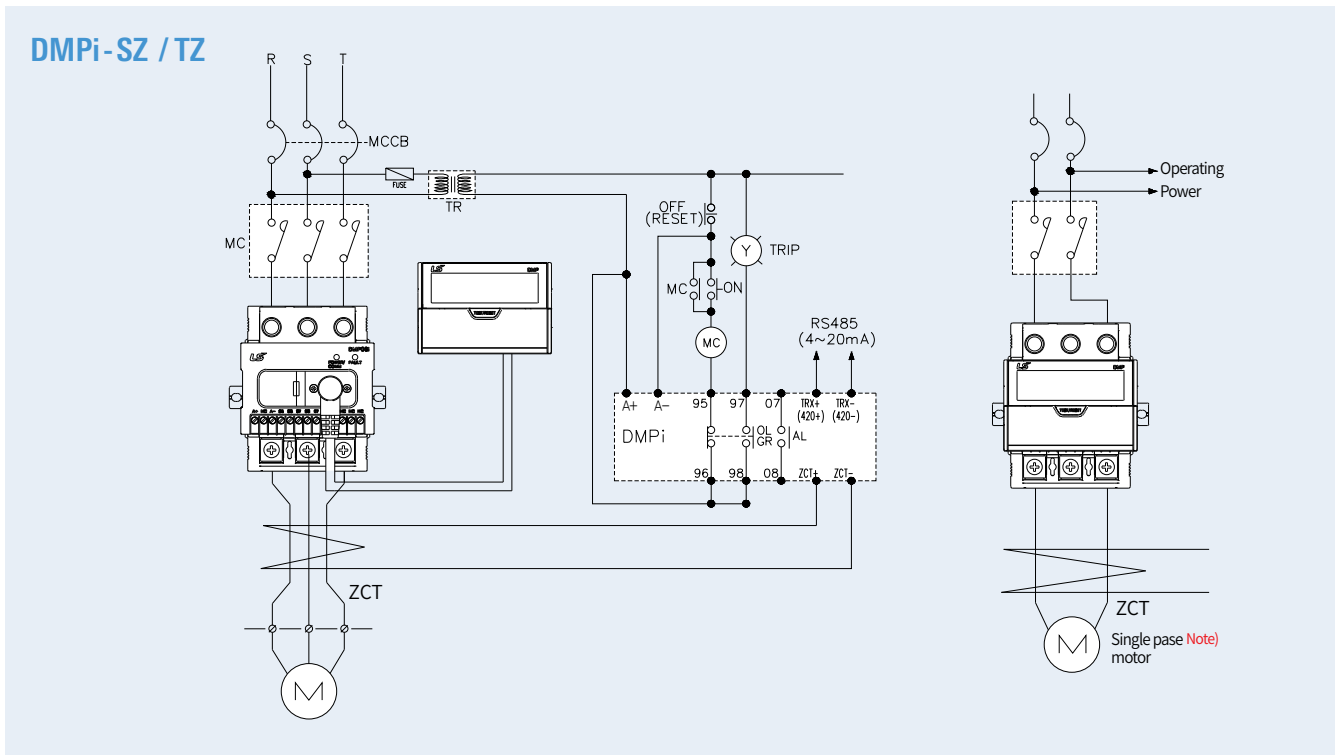

Note) 1. R-phase must be penetrated when connecting a single-phase motor. (Although there are S, T-phase CT in the product, values are measured based on R-phase.)

Terminal configuration / Wiring & cable connection

DMPi-SZ / TZ external ground fault protection type (1a1b large-capacity motor applied with external CT)

DMPi-SZ / TZ

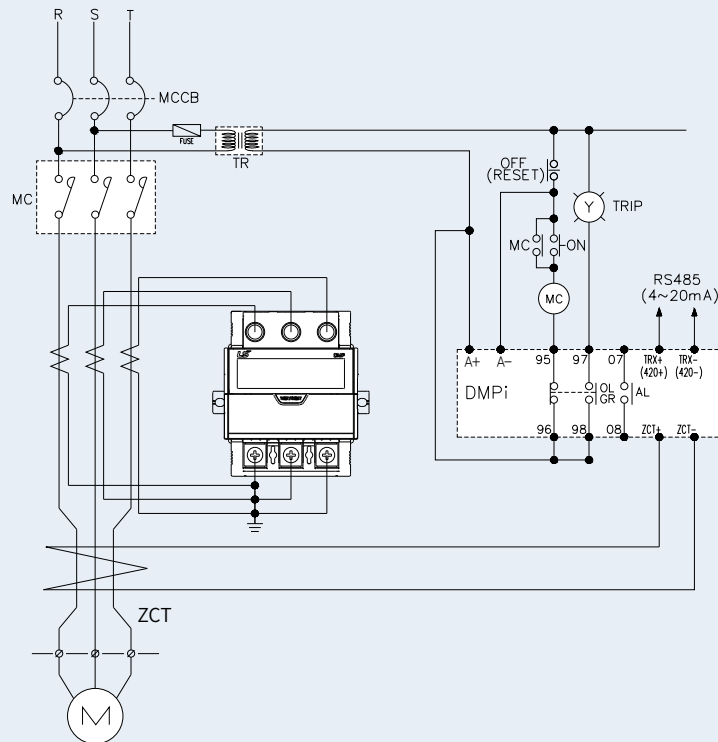

DMPi-SZ / TZ external ground fault protection type (2a)

DMPi-SZ / TZ

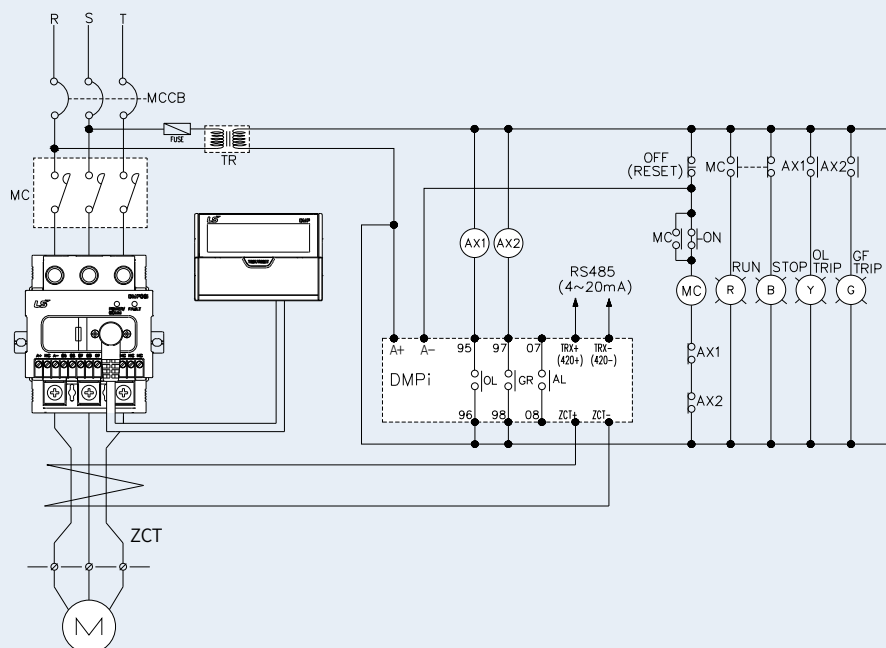

Terminal configuration / Wiring & cable connection

DMPi-SZI, TZI instant short-circuit protection and external ground fault protection type (1a1b large-capacity motor applied with external CT)

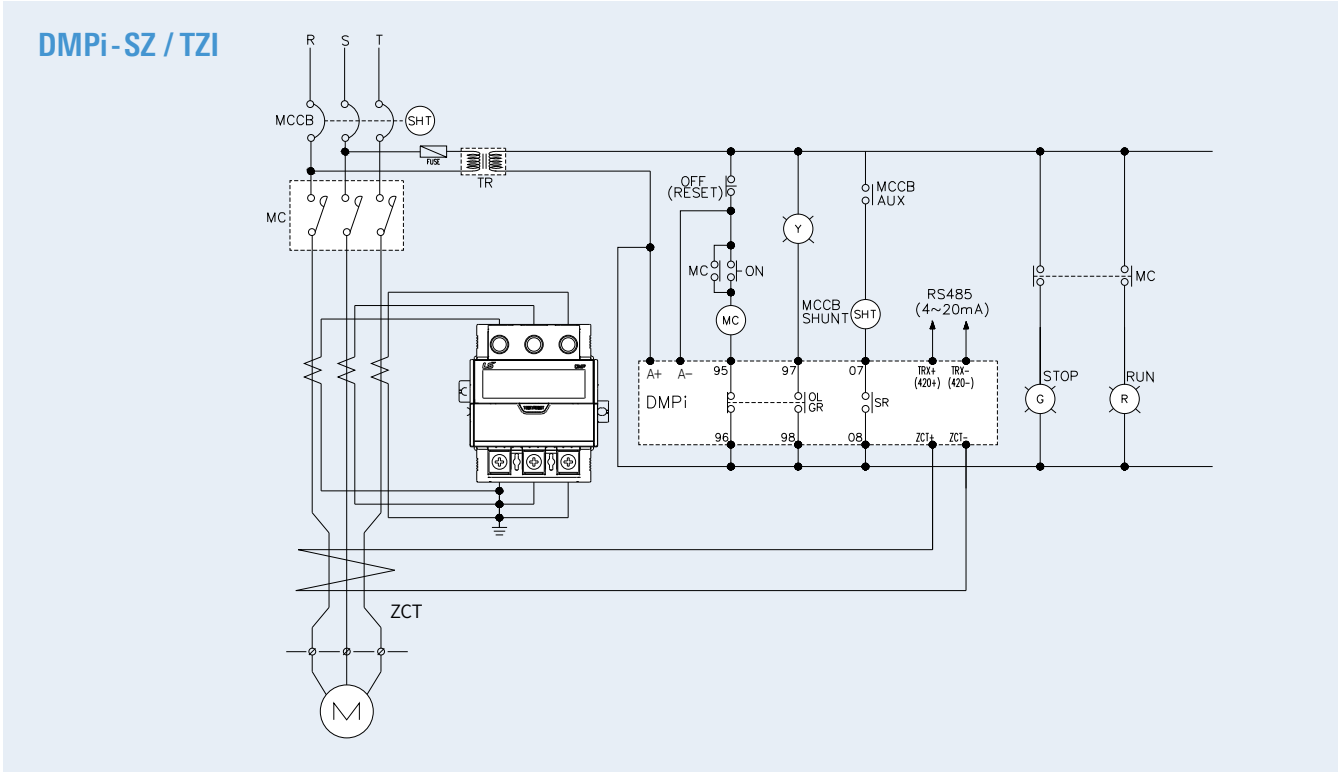

Unit : mm

Integrated terminal type

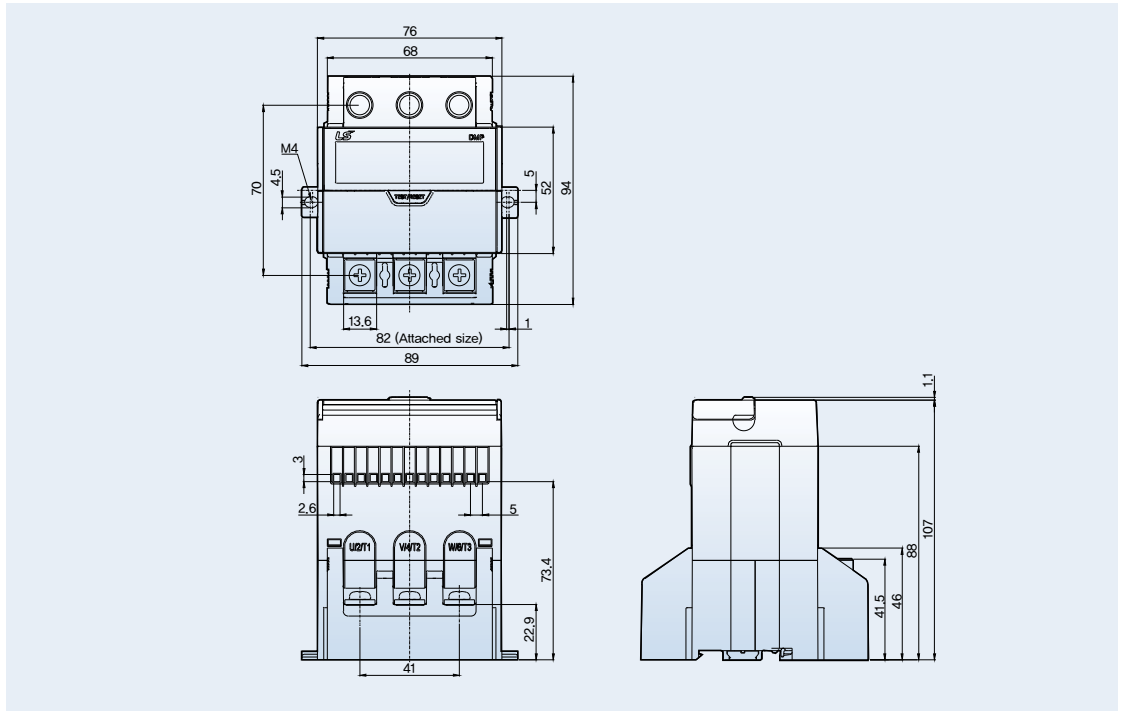

Separated terminal type

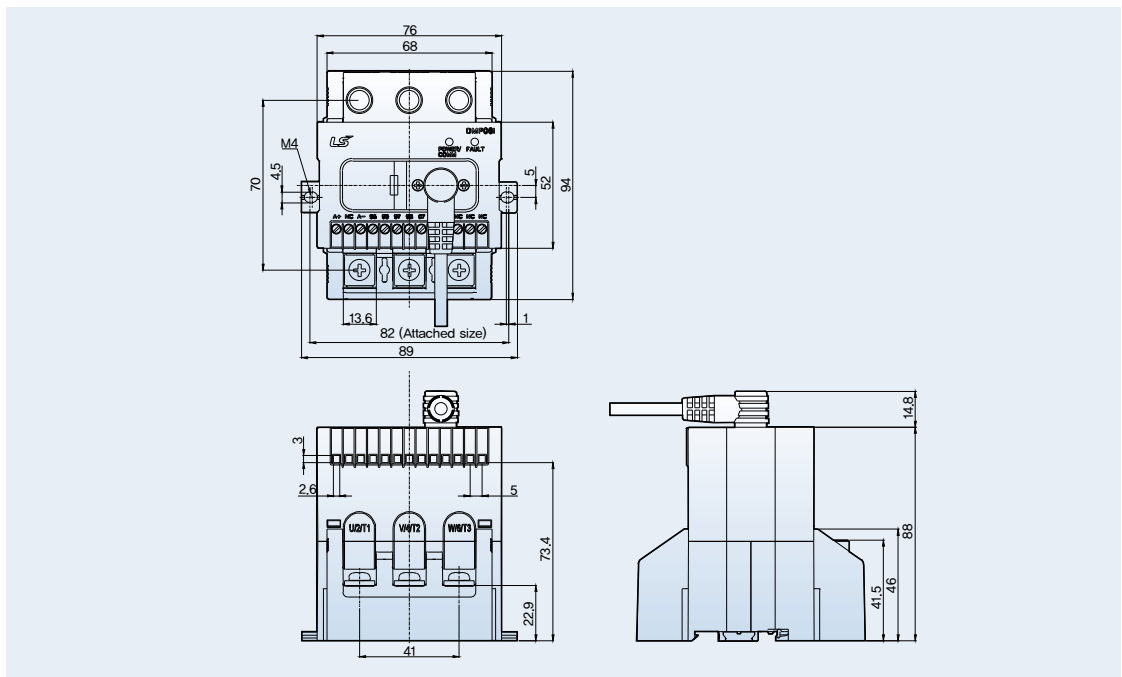

Panel insertion

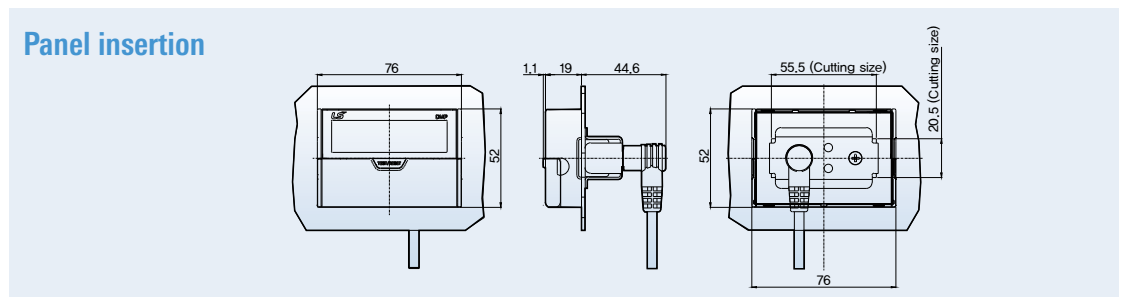

Dimensions

Unit : mm

Integrated penetration type

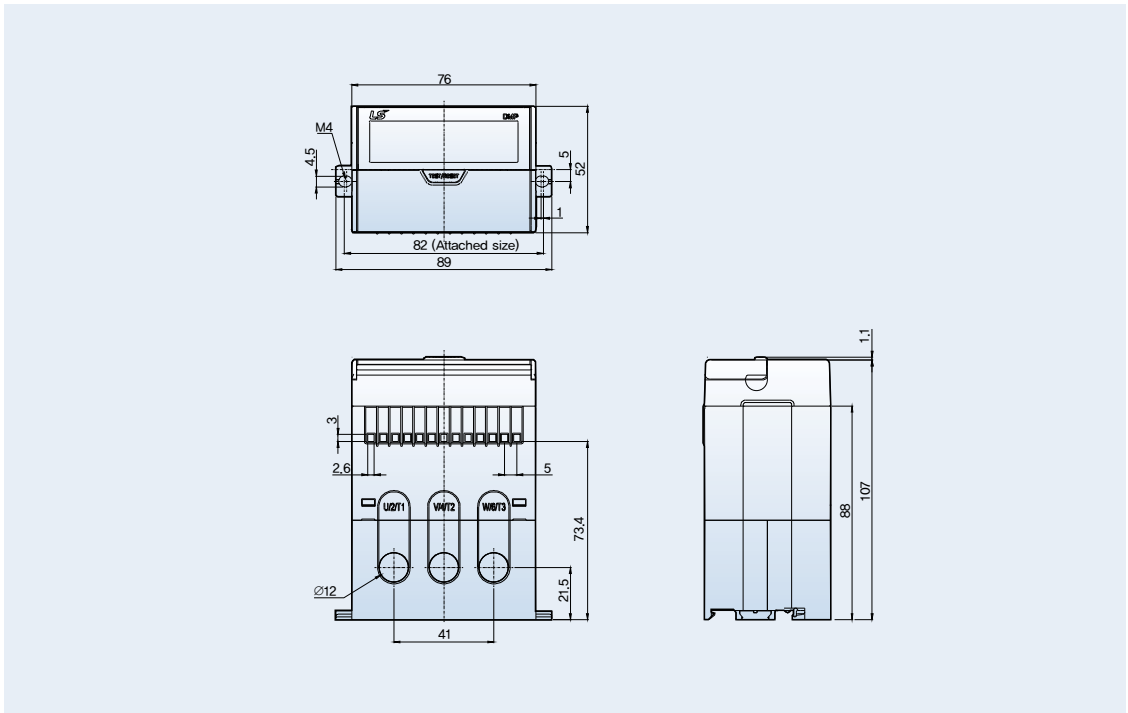

Separated penetration type

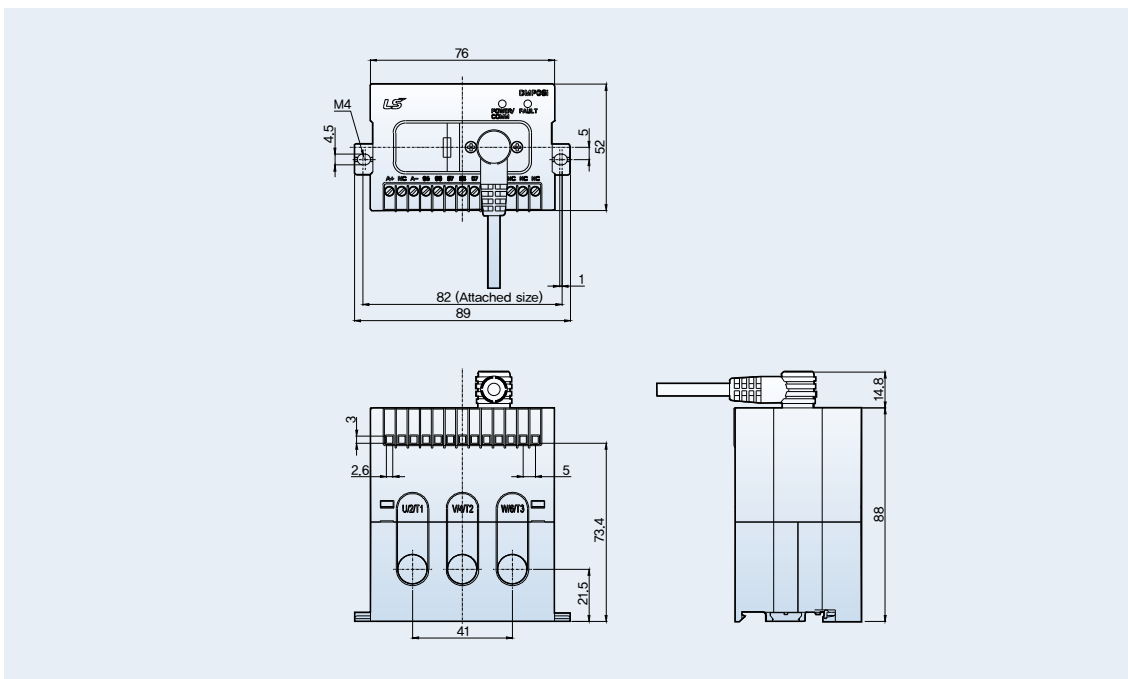

Panel insertion

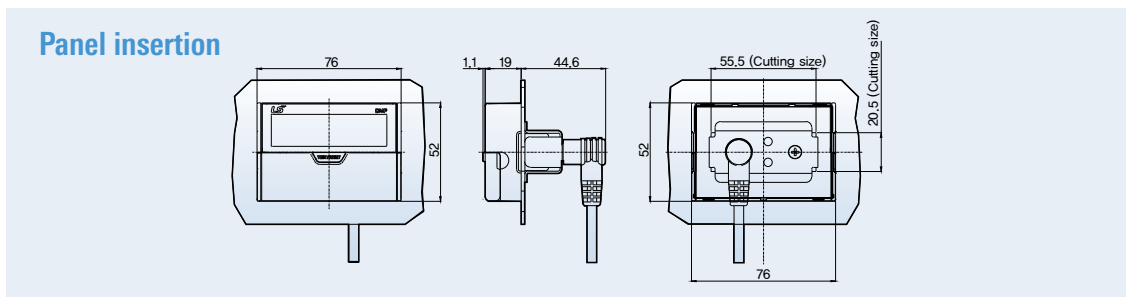



Safety Instructions

- For your safety, please read user's manual thoroughly before operating.
- Contact the nearest authorized service facility for examination, repair, or adjustment.
- Please contact qualified service technician when you need maintenance. Do not disassemble or repair by yourself!
- Any maintenance and inspection shall be performed by the personnel having expertise concerned.



- According to The WEEE Directive, please do not discard the device with your household waste.



www.lselectric.co.kr

■ Headquarters

127, LS-ro(hogye-dong) Dongan-gu, Anyang-si, Gyeonggi-Do, 14119, Korea

■ Seoul Office

LS Yongsan Tower, 92, Hangang-daero, Yongsan-gu, Seoul, 04386, Korea
Tel: 82-2-2034-4916, 4684, 4429

■ Overseas Subsidiaries

- **LS ELECTRIC Japan Co., Ltd. (Tokyo, Japan)**
Tel: 81-3-6268-8241 E-Mail: jschuna@lselectric.biz
- **LS ELECTRIC (Dalian) Co., Ltd. (Dalian, China)**
Tel: 86-411-8730-5872 E-Mail: jiheo@lselectric.com.cn
- **LS ELECTRIC (Wuxi) Co., Ltd. (Wuxi, China)**
Tel: 86-510-6851-6666 E-Mail: jdyim@lselectric.com.cn
- **LS ELECTRIC Vietnam Co., Ltd.**
Tel: 84-93-631-4099 E-Mail: jhchoi4@lselectric.biz (Hanoi)
Tel: 84-28-3823-7890 E-Mail: sjbaik@lselectric.biz (Hochiminh)
- **LS ELECTRIC Middle East FZE (Dubai, U.A.E.)**
Tel: 971-4-886-5360 E-Mail: hschoib@lselectric.biz
- **LS ELECTRIC Europe B.V. (Hoofddorf, Netherlands)**
Tel: 31-20-654-1424 E-Mail: europartner@lselectric.biz
- **LS ELECTRIC America Inc. (Chicago, USA)**
Tel: 1-800-891-2941 E-Mail: sales.us@lselectricamerica.com

■ Overseas Branches

- **LS ELECTRIC Tokyo Office (Japan)**
Tel: 81-3-6268-8241 E-Mail: jschuna@lselectric.biz
- **LS ELECTRIC Beijing Office (China)**
Tel: 86-10-5095-1631 E-Mail: chendm@lselectric.com.cn
- **LS ELECTRIC Shanghai Office (China)**
Tel: 86-21-5237-9977 E-Mail: khpaek@lselectric.com.cn
- **LS ELECTRIC Guangzhou Office (China)**
Tel: 86-20-3818-2883 E-Mail: chenxs@lselectric.com.cn
- **LS ELECTRIC Chengdu Office (China)**
Tel: 86-28-8670-3201 E-Mail: yangcf@lselectric.com.cn
- **LS ELECTRIC Qingdao Office (China)**
Tel: 86-532-8501-2065 E-Mail: wangzy@lselectric.com.cn
- **LS ELECTRIC Nanjing Office (China)**
Tel: 86-25-8467-0005 E-Mail: ylong@lselectric.com.cn
- **LS ELECTRIC Bangkok Office (Thailand)**
Tel: 66-90-950-9683 E-Mail: sjleet@lselectric.biz
- **LS ELECTRIC Jakarta Office (Indonesia)**
Tel: 62-21-2933-7614 E-Mail: jylee@lselectric.biz
- **LS ELECTRIC Moscow Office (Russia)**
Tel: 7-499-682-6130 E-Mail: jdpark1@lselectric.biz
- **LS ELECTRIC America Western Office (Irvine, USA)**
Tel: 1-949-333-3140 E-Mail: jwyun@lselectricamerica.com



Technical Question or After-sales Service

Customer Center-Quick Responsive Service, Excellent technical support

82-1644-5481